

FURUNO

OPERATOR'S MANUAL

MARINE RADAR

MODEL FR-1510D/1510DA



FURUNO ELECTRIC CO., LTD.
NISHINOMIYA, JAPAN

©FURUNO ELECTRIC CO., LTD.

9-52, Ashihara-cho,
Nishinomiya, Japan 662

Telephone: 0798-65-2111
Telefax: 0798-65-4200

•Your Local Agent/Dealer

All rights reserved. Printed in Japan

FIRST EDITION : JUN 1987
P : DEC. 16, 1993

(KAMO)

PUB. No. OME-33071
FR-1510D/1510DA



* 0 0 0 8 0 6 6 9 3 0 0 *

SUPPLEMENT TO OPERATOR'S MANUAL
 FOR FR-1505D/DA, FR-1510D/DA, FR-1525D/DA

To meet the requirements of any Administrations and customers, two versions of these radars are available, Regular or N-type. Fundamental performance is identical but operational arrangement is different on some points as follows.

	N-type	Regular type
Bearing Scale	1 degree interval scale outside the 190 mm radar effective diameter with readout every 10 degrees.	1 degree interval scale inside the 205 mm effective diameter. No bearing read out on scale.
VRM	1 VRM	2 VRMs
EBL	1 EBL (2 EBLs when setting guard zone)	2 EBLs
Guard Zone	Outer limit 6nm, inner limit 3nm, width of guard zone fixed to 0.5nm. Free sector.	Free range and sector.
Offcenter (Shift)	The sweep origin is shifted to stern side, 50% of the range on head-up mode only.	To any position within the range selected.
Zooming	Not provided.	Provided.
VRM unit	NM	NM or KM selectable with panel keys. KM can be changed to SM by internal DIP switch.
Keyboard (key label)	G-ZONE SET (for guard zone setting)	GUARD ALARM (for guard zone setting and alarm buzzer off)
	ACKN (for alarm buzzer off)	X2 ZOOM (for zooming)
Compliance	Netherlands and Germany	All other countries

TABLE OF CONTENTS

	<u>page</u>
SPECIFICATIONS	0-1 thru 0-7
CHAPTER 1 OPERATION	1-1 thru 1-16
GENERAL	1-1
BASIC OPERATION	1-1
Turning the Power On/Transmitting the Radar	1-1
Pulselength Selection	1-2
Range Selection	1-2
Tune Control Adjustment	1-2
Gain Control Adjustment	1-2
A/C SEA Control Adjustment	1-3
Brightness/Illumination Adjustment	1-3
CRT Brightness	1-3
Mark Brilliance	1-4
Heading Mark Brilliance	1-4
Operating Panel Illumination	1-4
Mode Selection	1-4
Head-Up Mode	1-4
North-Up Mode	1-5
Course-Up Mode	1-5
Head Set Mode	1-5
A/C RAIN/FTC Control Adjustment	1-6
Reducing Radar Interference	1-7
Erasing the Heading Mark/North Mark	1-7
RANGE AND BEARING MEASUREMENT	1-7
Range Measurement	1-8
VRM Unit Selection	1-8
Bearing Measurement	1-9
True Bearing Indication	1-9
SHIFTING THE DISPLAY	1-10
ZOOM FUNCTION	1-11
TARGET PLOTTING	1-12
ECHO AVERAGING	1-13
SETTING THE ALARM	1-14
Range Setting	1-14
Sector Setting	1-14
Alarm Setting	1-14
MAGNIFYING TARGET ECHOES	1-15

	<u>page</u>
DISPLAY AND FRONT PANEL LAYOUT	1-16
CHAPTER 2 APPLICATION	2-1 thru 2-5
MINIMUM AND MAXIMUM RANGES	2-1
Minimum Range	2-1
Maximum Range	2-1
RADAR RESOLUTION	2-1
Bearing Resolution	2-1
Range Resolution	2-2
BEARING ACCURACY	2-2
RANGE MEASUREMENT	2-2
FALSE ECHOES	2-2
Multiple Echoes	2-2
Side-lobe Echoes	2-3
Blind and Shadow Sectors	2-3
Virtual Image	2-3
POSITION FIXING WITH RADAR	2-4
Radar Range	2-4
Range and Bearing	2-4
Two Bearings	2-5
CHAPTER 3 MAINTENANCE	3-1 and 3-3
CHAPTER 4 TROUBLESHOOTING	4-1 thru 4-8
CHAPTER 5 INSTALLATION	5-1 thru 5-25
GENERAL	5-1
SCANNER UNIT INSTALLATION	5-1
Siting Considerations	5-1
Mounting and Connecting	5-1
Fixing the Scanner Housing to the Chosen Site	5-3
Connecting the Multicore Cable	5-3
Fabricating the Multicore Cable	5-7
Final Preparations Inside the Scanner Housing	5-8
Assembling the Radiator	5-9

	<u>page</u>
DISPLAY UNIT INSTALLATION	5-13
Siting Considerations	5-13
Mounting	5-14
Tabletop	5-14
Bulkhead	5-16
Connections	5-17
Fabricating the Power Cable	5-17
Connecting the Multicore Cable	5-17
Adjustment on the Power Supply Board	5-18
RECTIFIER UNIT INSTALLATION AND CONNECTION	5-19
ADJUSTMENT AT INSTALLATION	5-21
Preoperation Checks	5-21
Adjustments	5-22
Transmission Timing	5-22
Heading Alignment	5-23
Tuning Indicator Sensitivity	5-24
Main Bang Suppression	5-24
Magnetron Heater Voltage	5-25
APPENDIX A SETTING TOTAL ON TIME & TOTAL TX TIME	A-1
APPENDIX B DIP SWITCH	B-1 and B-2
APPENDIX C INSTALLING THE GC-1 GYRO CONVERTER	C-1 thru C-10
APPENDIX D ALTERATION OF RANGE UNITS FROM NM (NAUTICAL MILES) TO SM (STATUTE MILES)	D-1 and D-2
APPENDIX E MODIFICATION TO CHANGE ANTENNA IN LENGTH	E-1 thru E-4
APPENDIX F GSC BOARD CONNECTION FOR LOG AMP TYPE	F-1
LIST OF SCHEMATIC DIAGRAMS AND OUTLINE DRAWINGS	S-0
SCHEMATIC DIAGRAMS	S-1 thru S-13

SPECIFICATIONS

1. SCANNER UNIT

1. Radiator Length:	123cm	200cm	200cm	240cm**
2. Radiator Type:	XN-2	XN-3	XN-3A	XN-4A
3. Horizontal Beamwidth:	1.80°	1.23°	1.23°	0.95°
4. Vertical Beamwidth:	25°	25°	20°	20°
5. Sidelobe Attenuation: within + 10° of mainlobe (+ 20° for 123cm antenna)	-24dB	-24dB	-28dB	-28dB
outside + 10° of mainlobe: (+ 20° for 123cm antenna)	-30dB	-30dB	-32dB	-32dB

** Power supply must be 24VDC for 240cm antenna.

- | | |
|----------------------|---------------------------------|
| 6. Polarization: | Horizontal |
| 7. Antenna Rotation: | 24 rpm nominal (no wind load) |
| 8. Wind Load: | Relative wind 51.5 m/s (100kts) |

2. TRANSCEIVER UNIT

- | | |
|---|----------------------------|
| 1. Transmitting Tube: | Magnetron |
| 2. Frequency and Modulation: | 9410 ± 30MHz, PON (X-band) |
| 3. Peak Output Power: | 10kW |
| 4. Pulselength & Pulse Repetition Rate: | |

Pulselength	Pulse Rep. Rate (Hz)	Range (nm)									
		0.25	0.5	0.75	1.5	3	6	12	24	48	72
Short (SP) 0.08us	approx. 2100Hz	0.08us									
Middle 1 (M1P) 0.3us	"						0.3us				
Middle 2 (M2P) 0.6us	approx. 1200Hz						0.6us				
Long (LP) 1.2us	approx. 600Hz						1.2us				

- | | |
|------------------------|---------------------------------|
| 5. Modulator: | SCR line Type Pulse Modulator |
| 6. IF: | 60MHz |
| 7. Tuning: | Manual, with tuning marker |
| 8. Receiver Front End: | MIC (Microwave IC) |
| 9. Bandwidth: | D-TYPE DA-TYPE |
| Short pulse | 13MHz 7MHz |
| Med./Long pulse | 3MHz 3MHz |
| 10. Duplexer: | Circulator and Limiter |

3. DISPLAY UNIT

1. Indication System: PPI, daylight display
 2. Picture Tube: 15" rectangular CRT

3. Range:

4. Range Ring Interval:

5. Number of Rings:

0.25	0.5	0.75	1.5	3	6	12	24	48	72
0.05	0.1	0.25	0.25	0.5	1	2	4	8	12
5	5	3	6	6	6	6	6	6	6

6. Display Mode:

- 1) Head-up
- 2) Course-up*
- 3) North-up*
- 4) Head Set**

* gyrocompass required

** when no gyro is connected

7. Bearing Resolution:

better than $\left\{ \begin{array}{l} 2.4^\circ; \text{ radiator XN-2} \\ 1.83^\circ; \text{ radiator XN-3} \\ 1.83^\circ; \text{ radiator XN-3A} \\ 1.55^\circ; \text{ radiator XN-4A} \end{array} \right.$

8. Bearing Accuracy:

better than 1.0°

9. Range Discrimination:

better than 34m

10. VRM/Range Ring Accuracy:

1% or 10m, whichever is greater

11. Marks:

Heading Mark, North Mark, Bearing Scale, Range Ring, VRM1 & VRM2, EBL1 & EBL2, Tuning Marker, Guard Zone. Range in Use, Range Ring Interval, Display Mode (Head-up, North-up, Course-up, Head Set), Pulselength (SP, M1P, M2P, LP), Interference Rejector (IR), Alarm (GUARD), Gyro, Echo Stretch (ESR), Performance Monitor (PM), EBL, EBL Bearing Mode (TRU, REL), VRM, Echo Average (EAV1, EAV2, EAV3), Zoom (X2 ZOOM), Plotting (ECHO TRAIL), Fast Time Constant (FTC).

13. Echo Trail:

Continuous (max. 99min 59 sec), 30sec, 1min, 3min or 6min

14. Interference Rejector:

Built-in

15. Off-center Display:

Built-in

16. Zoom Function:

Selected target is doubled in size

4. ENVIRONMENTAL CONDITIONS

1. Vibration:

Total Amplitude	Vibration Cycle
+ 1.6mm	1 to 12.5Hz
± 0.38mm	12.5 to 25Hz
± 0.10mm	25 to 50Hz

2. Ambient Temperature:

Scanner Unit ----- -25°C to +70°C
 Display Unit ----- -15°C to +55°C

3. Humidity:

Relative Humidity 95% @ +40°C

5. POWER REQUIREMENTS

12/24/32VDC, 110W (24VDC), 12/32VDC mains can not be used for 240cm antenna.
 100/110/115/220/240VAC, 180VA (100V), 50-60 Hz, 1Ø (rectifier required)

6. COLOR

Scanner Unit:
 Display Unit:

Munsell N9.5
 2.5GY-5/1.5 Embossed T25 (Cabinet)
 N3.0 Newton No.5 (Control Panel)

COMPLETE SET

No.	Name	Type	Q'ty	Wt. (kg)	Remarks
1	Scanner Unit	XN2-C2P7N2N-014(A)	1	33	123cm
		XN3-C2P7N2N-014(A)		37.5	200cm
		XN3A-C2P7N2N-014(A)		36.5	200cm
		XN4A-C2P7N2N-014(A)		38.5	240cm
2	Display Unit	RDP-059	1	21	
3	Accessories	FP03-02300	1set		
4	Installation Materials	CP03-00300 (15m) CP03-00320 (20m) CP03-00330 (25m) CP03-00340 (30m)	1set		CP03-01210 (for scanner) + CP03-01210 (for display) + Cable (Specify length)
5	Spare Parts	SP03-03200	1set		

ACCESSORIES

No.	Name	Type	Code	Q'ty	Remarks
1	Vinyl Cover	03-024-0401	000-801-325	1	
2	Handle	03-001-1215-3	300-112-153	2	
3	Phillips Head Screw	M6x18 C2700W	000-861-479	4	for handle installation
4	Rosette Washer	M6 C2700W	000-864-910	4	
5	Hood Assembly	FP03-02310	008-101-630	1	

SPARE PARTS

No.	Name	Type	Code	Q'ty	Remarks
1	Fuse	XB02C31PRO	000-110-297	1	display unit
2	Fuse	FGBO 25A 125VAC	000-549-016	2	"
3	Fuse	FGBO 0.5 125VAC	000-549-060	2	"
4	Fuse	FGBO-A 5A 125VAC	000-549-064	2	"
5	Fuse	FGBO 10A 125VAC	000-549-065	2	"
6	Carbon Brush	MG120-56x6x11	000-631-716	2	for scanner motor
7	L-handle Socket Wrench	M8 use, diagonal 13mm	000-830-110	1	for scanner unit
8	Spare Parts Box	for F710	000-831-610	1	
9	Hex Wrench	1.5m/m diagonal	000-830-112	1	display unit
10	Hex Wrench	4m/m diagonal	000-830-132	1	display unit

OPTION

No.	Name	Type	Code	Remarks
1	External Buzzer	OP03-21	000-030-097	
2	Gyro Converter	GC-1		Built in Display Unit
3	Video Plotter	RP-1		
4	Rectifier	RU-1746B-2		AC mains

INSTALLATION MATERIALS

Display Unit

No.	Name	Type	Code	Q'ty	Remarks
1	Crimp-on Lug	8NK4	000-538-180	6	pwr. cable connection
2	Crimp-on Lug	FV2-4 blue	000-538-118	4	rectifier
3	Hexagon Nut	M3 C2700W MBNI2	000-863-204	2	for fixing signal cable connector to DJ-1
4	Flat Washer	M3 C2600P MBNI2	000-864-104	2	
5	Spring Washer	C5191W MBNI2	000-864-204	2	
6	NH Connector	03-302(4P)	008-300-570	1	bearing signal input
7	Signal Cable Assembly	S03-4-15 (15m) S03-4-20 (20m) S03-4-25 (25m) S03-4-30 (30m)	008-299-230 008-299-280 008-299-260 008-290-270	1	Select one
8	Power Cable	P03-1-15 (15m)	000-560-634	1	CVV-S 8x2C (option)

Scanner Unit

No.	Name	Type	Code	Q'ty	Remarks
1	Crimp-on Lug	FV-2-4 blue	000-538-118	1	for inner shield of signal cable
2	Crimp-on Lug	FV1.25-L3	000-538-111	29	for core of signal cable
3	Crimp-on Lug	320882	000-537-110	1	coax. cable
4	Hexagon Bolt	M12x60 SUS304	000-862-191	4	scanner unit installation
5	Hexagon Nut	M12 SUS304	000-863-112	4	
6	Flat Washer	M12 SUS304	000-864-132	4	
7	Spring Washer	M12 SUS304	000-864-263	4	
8	Seal Washer	03-001-3002-0	300-130-020	4	
9	Corrosion-proof Rubber	03-001-3001-0	300-130-010	1	
10	Grounding Wire	RW-4747	000-566-000	1	for grounding scanner unit
11	Hexagon Bolt	M6x25 SUS304	000-862-180	1	earth bolt use
12	Hexagon Nut	M6 SUS304	000-863-109	1	
13	Flat Washer	M6 SUS304	000-864-129	3	
14	Spring Washer	M6 SUS304	000-864-260	1	

Radiator

No.	Name	Type	Code	Quantity		
				*1	*2	*3
1	Hexagon Nut	M8 SUS304	000-863-110	4	6	4
2	Hexagon Bolt w/split pin	M8x30 SUS304	000-862-151	4	6	4
3	Hexagon Bolt w/split pin	M8x25 SUS304	000-862-149	4	-	4
4	Spring Washer	M8 SUS304	000-864-262	8	6	8
5	Flat Washer	M8 SUS304	000-864-130	12		
6	Hexagon Bolt	M4x16 SUS304	000-862-113	8	-	-
7	Hexagon Screw B w/split pin	M4x16 SUS304	000-882-042	-	8	8
8	Hexagon Screw A w/split pin	M6x25 SUS304	000-881-923	-	6	-
9	Hexagon Bolt w/split pin	M4x30 SUS304	000-862-116	-	-	2
10	Spring Washer	M4 SUS304	000-864-256	8	-	2
11	Flat Washer	M4 SUS304	000-864-126	8	-	2
12	O-ring	AS568-125	000-851-840	2		
13	Three Bond	1211 (50g)	000-854-118	1		
14	Waveguide Clamp (1) E type	RSB-2006-1	360-220-061	-	1	1
15	Waveguide Packing (1)	RSB-2008-0	360-220-080	-	1	-
		03-003-4003-0	300-340-030	-	-	1
16	Washer	RSG-1002-0	360-710-020	-	6	-
17	Hexagon Screw B w/split pin	M4x25 SUS304	000-882-043	-	2	-

*1 123 cm (XN-2 scanner)

*2 200 cm (XN-3 scanner)

*3 200/240 cm (XN-3A/XN-4A scanner)

CHAPTER 1 OPERATION

GENERAL

This radar is basically very easy to operate. If you change a control setting you will see the associated reaction almost immediately on the screen. Key operation is confirmed by a beep tone, while unacceptable key entry is communicated by a series of beep tones.

Operating personnel should familiarize themselves with all the operating controls so as to make the best possible use of the equipment. A brief explanation of the function of each control and the location of display screen indicators are given in the illustration on page 1-16.

BASIC OPERATION

Turning the Power On/Transmitting the Radar

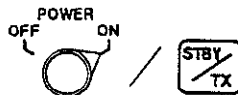

After having confirmed that there are no obstructions around the scanner, turn the POWER and SCANNER switches to ON. (The scanner switch is located behind the preset compartment. It may be permanently set to ON.) DIP switch settings, program no., results of the ROM & RAM checks, total on time, total TX time, and the 3-minute timer are displayed. The 3-minute timer begins counting down from 3:00 to 0:00, whereupon it changes to "ST-BY," indicating the radar is ready to transmit.

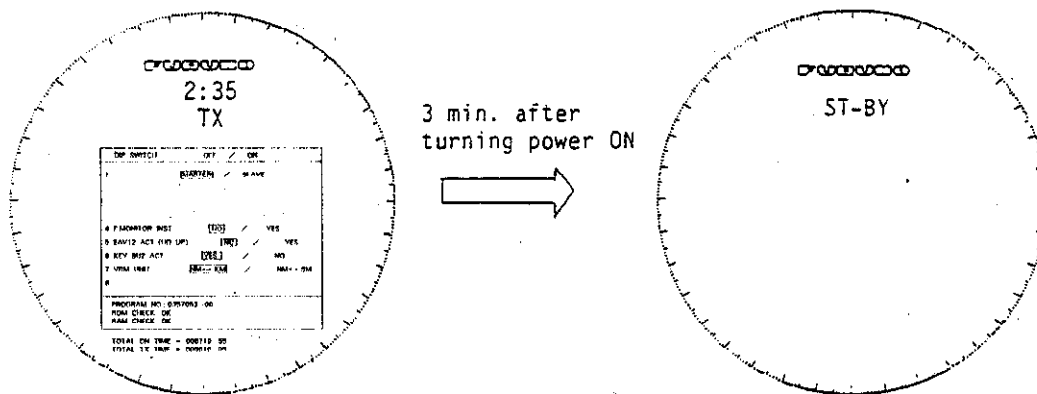

Fig. 1-1

When the message ST-BY appears on the screen, press the [STBY/TX] touchpad to begin transmission. The display screen lights up, and any echoes received from targets are displayed on the screen. (If the [STBY/TX] touchpad is pressed during the 3-minute warm up period, TX appears below the timer indication and the radar will begin transmitting immediately at 0:00.)

To temporarily suspend transmission, press the [STBY/TX] touchpad to display ST-BY on the screen.

NOTE: Whenever the [STBY/TX] touchpad is pressed to begin transmission, or the [RANGE (+) (-)], [PULSE], [SHIFT], [MODE], or [X2 ZOOM] touchpad is pressed, the cross hair cursor is displayed on the screen for 3 sec before being erased.

Pulselength Selection



The [PULSE] touchpad is used to select the pulselength. At the "short pulse length" position, picture definition in the 1.5 to 24 nm ranges is improved. And at the "long pulse" position, the detection of echoes is improved. The pulselength selected is indicated at the upper left-hand corner of the screen: SP, short pulse; M1P, medium pulse 1; M2P, medium pulse 2; or LP, long pulse.

The pulselength and pulse repetition table on the specifications shows the pulselength selectable in each range.

Range Selection



The RANGE control is used to select the RANGE. The range selected determines automatically the fixed range ring interval. Press the [+] touchpad to increase the range, or press the [-] touchpad to lower the range. The range selected and the fixed range interval are indicated at the upper left-hand corner of the screen.

TUNE Control Adjustment



The TUNE control is used to tune the receiver in the transmitter. For the first 10 minutes of operation the tuning should be checked periodically because the transmitter has not stabilized yet. Readjustment after the first 10 minutes is normally not required.

Tuning is made easy by the use of the tuning bar provided at the upper right-hand side of the display screen. The TUNE control is so adjusted to display the longest tuning bar.

To tune the receiver, first turn the A/C SEA control fully counterclockwise and set the range to maximum. Turn the TUNE control between its extremes until the longest tuning bar (between 4 and 5 tuning markers) is obtained.

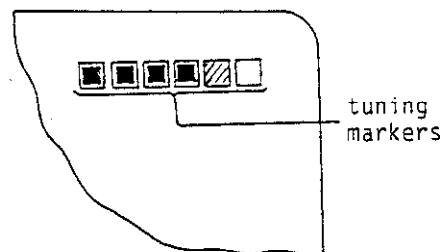

Fig. 1-2 Tuning Bar

GAIN Control Adjustment



The GAIN control is used to adjust the sensitivity of the receiver, and thus the strength of echoes as they appear on the screen. It is adjusted so that the speckled noise background is just visible on the CRT.

To properly set the gain, first select one of the long ranges--the speckled background is more apparent. Turn the GAIN control clockwise slowly; you should be able to see the speckled background appear when the position of the control is between 2 and 3 o'clock. If you set up for too little gain, weak echoes may be missed. If you turn the control too far clockwise, yielding too much speckled noise background, targets may be missed because

of the poor contrast between desired echoes and the background noise on the display.

A/C SEA Control Adjustment

Sea clutter appears on the screen as a large number of small echoes (see Fig. 1-3) which might affect radar performance. The action of the A/C SEA circuit is to reduce the amplification of echoes at short ranges (where clutter is the greatest) and progressively increase amplification as the range increases, so that amplification will be normal at those ranges where sea clutter is not experienced. The control is effective to a maximum of about 6 miles.

The proper setting of the A/C SEA control is so that the clutter is broken up into small dots, and small targets become distinguishable. If the control is not sufficiently advanced, other targets will be hidden in the clutter, while if it is set too high, sea clutter and targets will both disappear from the screen. As a general rule of thumb, turn the control clockwise until the clutter has disappeared leeward, but a little is still visible windward. Always leave a little clutter visible on the screen, this ensures weak echoes will not be suppressed. If no clutter is visible on the screen, leave the control in the fully counterclockwise position.

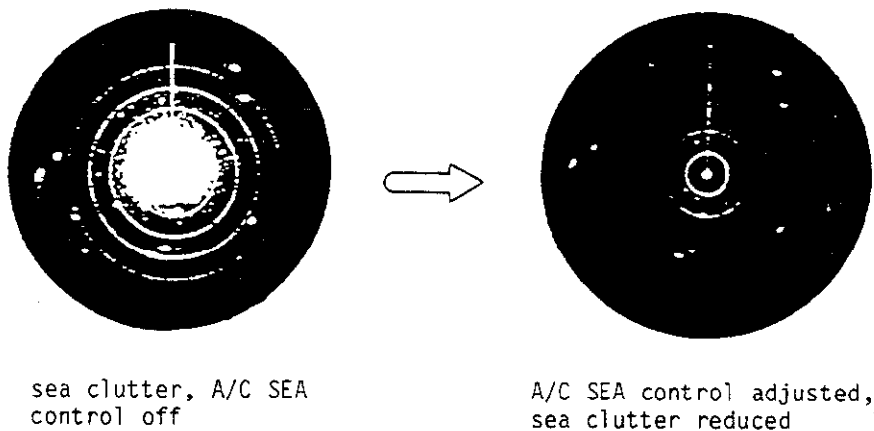

Fig. 1-3 Adjusting the A/C SEA Control

Brightness/Illumination Adjustment

CRT Brightness

The "BRILL" (Brilliance) control, located on the sub operating panel, adjusts the brightness of the CRT. Turn it clockwise to increase the intensity of the radar echoes blips, legends and markers. Adjust it so that radar echo blips may be observed clearly.

Mark Brilliance



The [MARK BRILL] touchpad is used to adjust the brilliance of the various marks displayed on the screen; i.e., VRMs, EBLs, range rings, north mark (gyro connected), and guard zone. There are four levels of brilliance: low, medium, medium high and high. Each time the touchpad is pressed the brilliance changes in the above sequence.

Heading Mark Brilliance



Heading Mark brilliance may be adjusted by pressing the [HM BRILL] touchpad. There are four levels of brilliance: low, medium, medium high and high. Each time the touchpad is pressed the brilliance changes in the above sequence.

Operating Panel Illumination



The PANEL DIM (panel dimmer) control adjusts the illumination for both the touchpad and sub operating panels.

Mode Selection



The [MODE] touchpad is used to select the mode. There are either two or three modes selectable, Head-Up (HU), North-Up (NU), Course-Up (CU) or Head Set (HS), depending on whether a gyro interface is connected or not. Each time the touchpad is pressed the mode changes in the following sequence.

with gyro interface -----> HU → NU → CU

without gyro interface -----> HU → HS

The mode selected is indicated by "HEAD UP," "NORTH UP," "COURSE UP" or "HEAD SET" at the top left-hand side of the screen.

Head-Up Mode

The picture is orientated so that the heading mark appears at the top of the screen. This mode is most suitable for navigation in congested areas or narrow channels.

Note that the north mark appears only when a gyrocompass is connected.

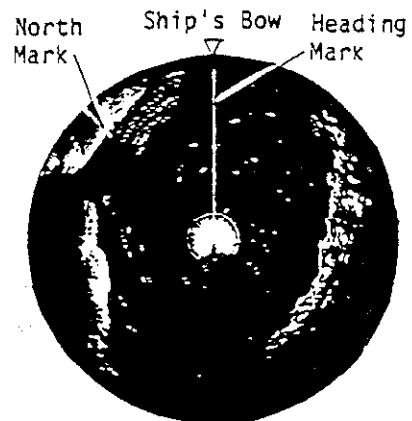

Fig. 1-4 Head-Up Mode Display

North-Up Mode

The radar picture is stabilized so that the North is at the top of the screen and the heading mark changes according to the orientation of the ship's heading. This mode is suitable for both measuring the ship's position and as a navigation monitor on a navigational chart. The picture is stabilized against yaw of the vessel, reducing the smearing of target echoes.

This mode is available only when a gyro-compass is connected.

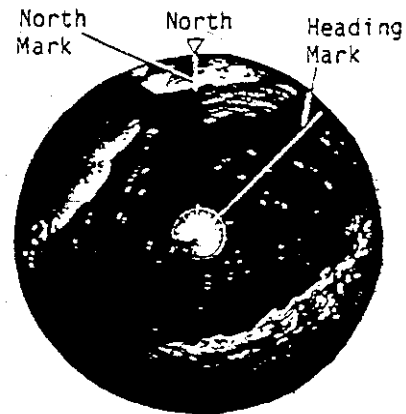

Fig. 1-5 North-Up Mode Display

Course-Up Mode

Press the [MODE] touchpad for the CU mode at the moment the ship's bow is oriented to the desired direction (ship's course to port, waypoints, etc.), and the picture is stabilized with the desired picture direction at the top of the screen. The heading mark changes according to the orientation of ship's heading. The picture is stabilized against yaw of the vessel.

This mode is available only when a gyro-compass is connected.

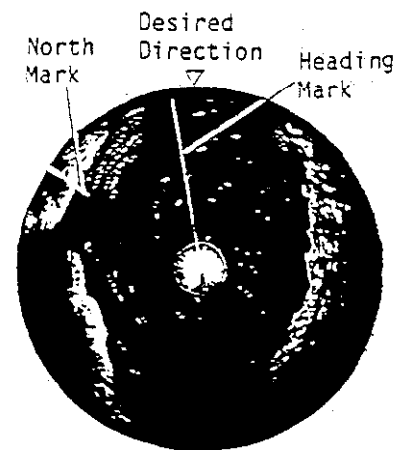

Fig. 1-6 Course-Up Mode Display

Head Set Mode

The heading mark may be moved to the desired direction by using EBL and its rotary knob control.

Select the Head-up Mode; press the ON portion of the EBL touchpad to display EBL (EBL1 or EBL2); set EBL to the desired direction by rotating the rotary knob (1-7a). Then select the Head Set Mode, and the heading mark will move to where the EBL is located as shown in 1-7b. Note that this mode is available only when a gyrocompass is not connected.

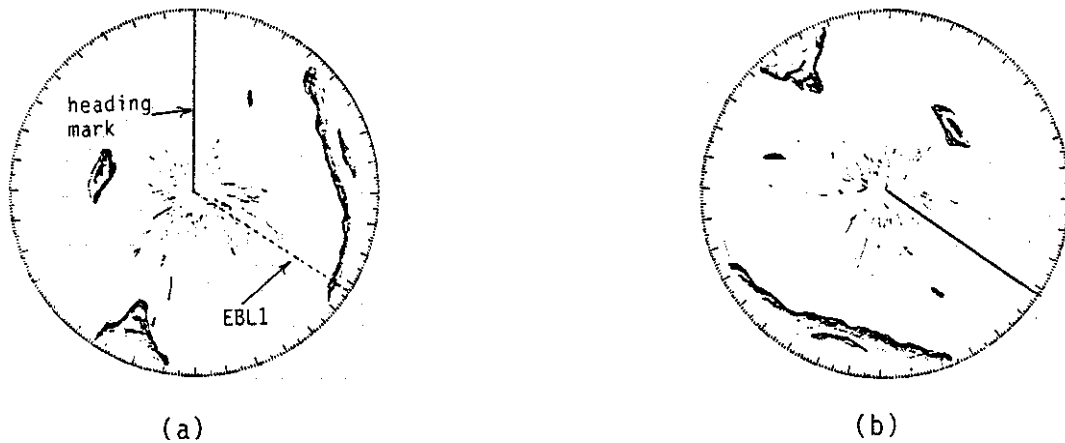

Fig. 1-7 Head Set Mode Display

A/C RAIN/FTC Control Adjustment



The echoes of ships operating inside rain, hail, or snowstorms may be hidden by on-screen rain clutter. Rain clutter is easily recognizable by its wool-like appearance on-screen. When this type of interference obscures a large area of the screen, you would use the A/C RAIN/FTC control to reduce the clutter.

When only a slight amount of clutter is visible on the screen, turn the control clockwise to distinguish targets from the clutter. In heavy storms or partial clutter, pull out the control and adjust it to clarify the picture. (The indicator "FTC" is displayed on the screen when the control is pulled out.) Besides using it in heavy storms, the FTC may also be used in clear weather to separate groups of echoes on a congested short range picture. In all cases use discretion when adjusting the control. Advancing it too far clockwise may erase targets from the screen.

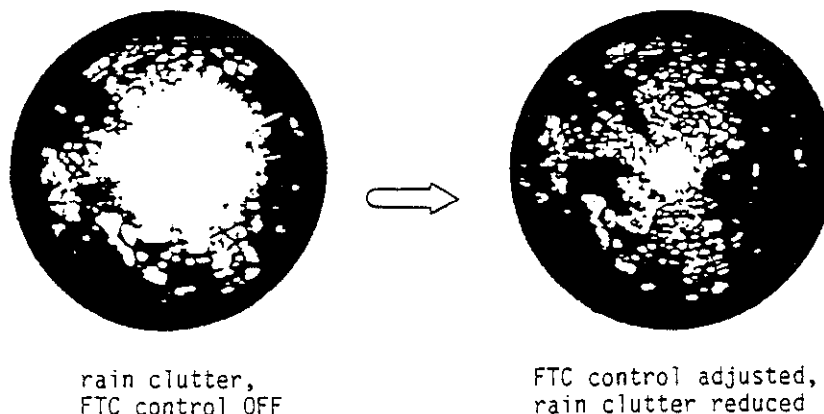

Fig. 1-8 Effect of the A/C RAIN/FTC Control

For log amplifier specification

Turn the A/C RAIN control clockwise for best discrimination of the target. Refer to page 1-15 for operation of FTC ON/OFF control.

Reducing Radar Interference

Radar interference may occur when in the vicinity of another shipborne radar operating in the same frequency band. It appears on the screen often as a large number of bright dots either scattered at random or in the form of "curved spokes" (see Fig. 1-9). This type of interference can be reduced by activating the Interference Rejector circuit. Press the [IR] touchpad to activate the circuit. The IR indicator appears at the upper right-hand corner of the screen. Press the touchpad again to switch off the circuit when no interference exists, otherwise weak targets may be missed.

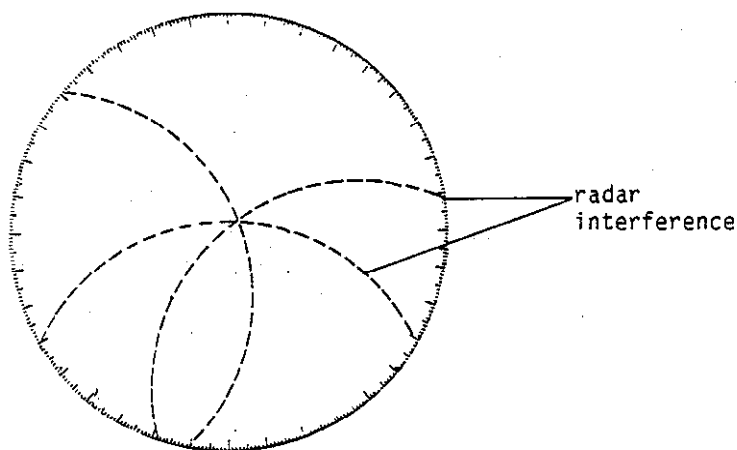

Fig. 1-9 Radar Interference

Erasing the Heading Mark/North Mark

When the radar is turned on, the heading mark is displayed. The north mark is also displayed if a gyrocompass is connected. When the heading mark or north mark masks or hinders recognition of a small target echo, press and hold the [HM OFF] touchpad to temporarily erase them. Release hold to redisplay them.

In addition to erasing the heading mark/north mark this touchpad can, when pressed and held while pressing the [VRM] or [EBL] touchpad, alternate between NM and KM units for the VRM(s) or select true or relative bearing indication for the EBL(s). For further details, see the section on Range and Bearing Measurement.

RANGE AND BEARING MEASUREMENT

The range to a target may be measured with the fixed range rings, erased/displayed by pressing the [RING] touchpad, or a Variable Range Marker (VRM). And the bearing of a target may be measured by an Electronic Bearing Line (EBL).

Selection and operation of the markers used to measure range and bearing are simple. At each bottom corner of the display unit there is a touchpad control, EBL ON/OFF on the left corner and VRM ON/OFF on the right corner, and a rotary knob. The ON and OFF touchpads on each touchpad control are

used to display and erase a marker from the screen. Each rotary knob operates two markers, VRM1/VRM2 or EBL1/EBL2. (Whenever power is applied and the radar is set to transmit VRM1 and EBL1 and their indicators are displayed on the screen.) The marker currently operable by a rotary knob is determined by the cursor; the marker whose indicator is framed by it is operable. To transfer control to the other marker, press the ON portion of the touchpad.

To erase a marker from the screen, press the OFF portion of the touchpad. The marker and its indicator are erased. If two alike markers are displayed when the OFF portion is pressed, the indicator not framed by the cursor is erased.

NOTE: For N-type version, the No.2 VRM and No.2 EBL are not provided.

Range Measurement  

The range to a target is roughly measured with the range rings, which are displayed/erased by pressing the [RING] touchpad.

For more accurate measurement of the range to a target you would activate the VRM. Press the ON portion of the [VRM] touchpad until the cursor is on the VRM indicator of the VRM you want to operate. Next, rotate the VRM rotary knob control until the circle described by the VRM just touches the inside edge of the target blip (see Fig. 1-10). The range to the target is shown at the lower right-hand corner of the screen; VRM1 indicator on top and VRM2 indicator below it.

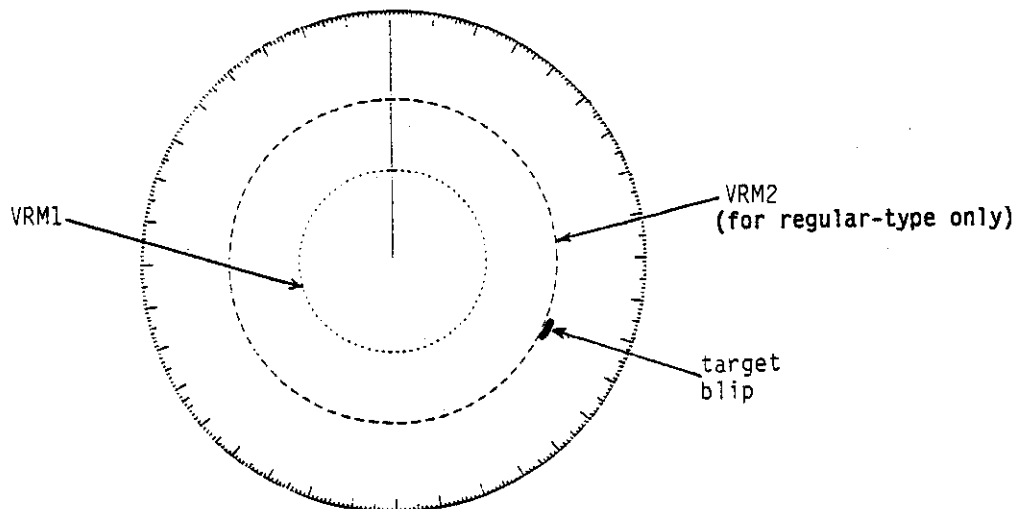

Fig. 1-10 Measuring Range With a VRM

VRM Unit Selection  &  (for regular-type version)

The unit of measurement for the VRM1/VRM2 can be changed from NM to KM (and vice versa). Press the ON portion of the [VRM] touchpad to place the cursor on the VRM indicator you want to change, and then press and hold the [HM OFF] touchpad while pressing the ON portion of the [VRM] touchpad.

Bearing Measurement



Press the ON portion of the [EBL] touchpad until the cursor is on the EBL indicator of the EBL you want to operate. Then, rotate the EBL rotary knob control until the EBL bisects the target blip (see Fig. 1-11). The measured bearing is shown at the lower left-hand corner of the display screen; EBL1 indicator on top and EBL2 indicator below it. (Ship's heading is shown above the EBL1 indicator when a gyrocompass is connected.)

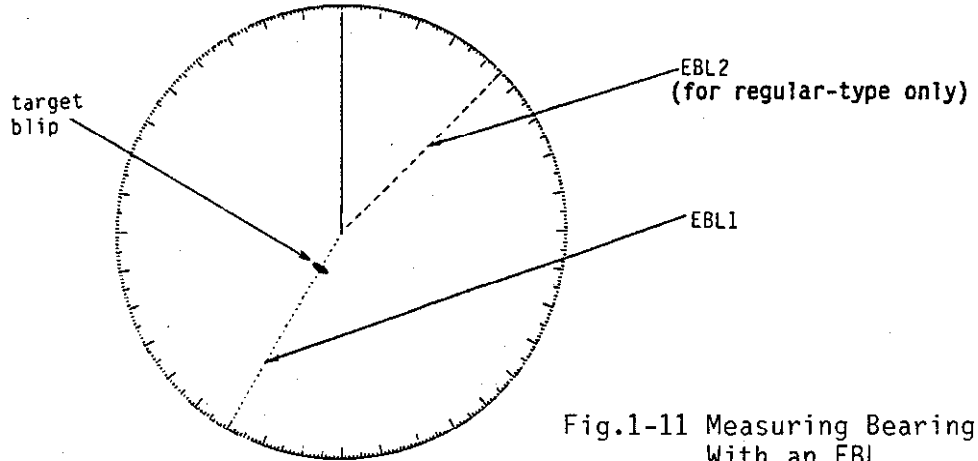
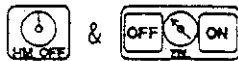

Fig.1-11 Measuring Bearing With an EBL

True Bearing Indication



If this radar is connected to a gyrocompass, you can get true bearing indication. Select the Head-up mode; press the ON portion of the [EBL] touchpad until the cursor is over the indicator desired (this step is unnecessary when only one EBL marker is displayed). Then, press and hold the [HM OFF] touchpad while pressing the ON portion of the [EBL] touchpad.

Range & Bearing Between Two Targets (Use of offset EBL)

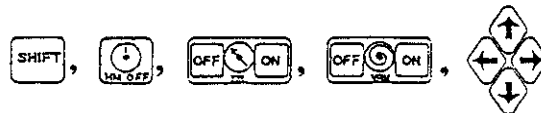





The EBL1 origin and VRM1 center can be offset to measure the range and bearing between any two targets on the screen, or predict movement of another ship.

1. Move the cross hair cursor to one of the two targets selected with four cursor shift touchpads. Press the [SHIFT] touchpad while keeping the [HM OFF] touchpad pressed, and the EBL1 origin and the VRM1 center are offset to the cross hair cursor intersection.
2. Adjust the EBL control so that EBL1 bisects the other target in concern, and adjust the VRM control so that VRM1 rests on the inner edge of the target. Now, the range and bearing between the two are given by VRM1 and EBL1 indicators.
3. To predict another ship's course, place EBL1 over the target after passing several minutes. If EBL1 bisects own ship, the possibility of collision exists. Refer to Fig.1-14 on page 1-12.

SHIFTING THE DISPLAY & ///



The display can be shifted at any position in radar screen. The primary advantage of the shifted (off-center) display is that for any particular range setting the view ahead, behind or on the sides of own ship can be extended. This lessens the requirement for changing the range.

The cross hair cursor, which may be maneuvered by the cursor shift touchpads (///), is used to select the area to be shifted.

Note that the maximum range of the shifted display function is limited to 1.6 times the original range.

Procedure

1. Press a cursor shift touchpad to present the cross hair cursor on the screen (a). Set the cursor on the area desired (b). After releasing hold of the touchpad, the cursor will flash 3 sec before being erased.

NOTE 1: The cursor can be replaced in the center of the screen by pressing the  and  touchpads simultaneously.

NOTE 2: If, when pressing a cursor shift touchpad the cursor reaches the edge of the bearing scale, a series of beep tones will be generated, telling you to that the cursor cannot be moved farther outward.

2. Press the [SHIFT] touchpad, and the selected area is off-centered (c). The heading mark is shifted to where the cursor was last positioned and the cursor is redisplayed 3 sec before being erased.
3. To cancel the shift function, press the [SHIFT] touchpad again.

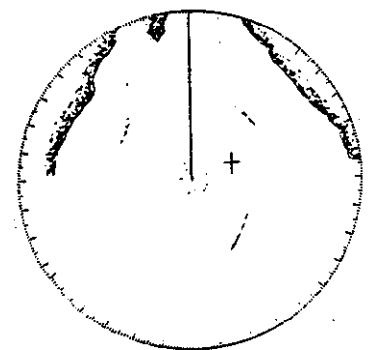

(a)

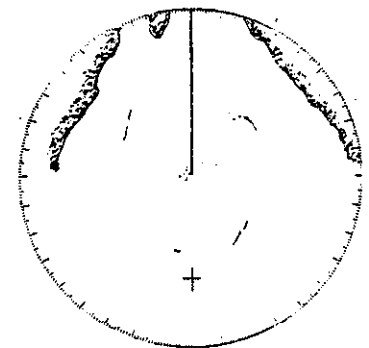

(b)

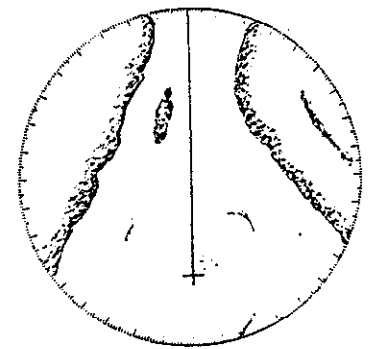

(c)

Fig. 1-12 Shifting the Display



ZOOM FUNCTION  &  /  /  /  (for regular-type version only)

The area between own ship and an arbitrary location can be doubled with the zoom function. This function lets you take a closer look at an area of interest without changing the range in use.

Note that this function is not available when the shift function is on. If you attempt to activate it when the shift function is on, successive beep tones will be generated, informing you of unacceptable key entry.

Procedure

1. Press any cursor shift touchpad to display the cross hair cursor (a); operate the cursor shift touchpads until the cursor is near the target (b). After releasing hold of a cursor shift touchpad, the cursor flashes 3 sec. before being erased from the screen.

NOTE 1: The cursor can be replaced in the center of the screen by pressing the  and  touchpads simultaneously.

NOTE 2: If, when pressing a cursor shift touchpad the cursor reaches the edge of the bearing scale, a series of beep tones will be generated, telling you to that the cursor cannot be moved farther outward.

2. Press the [X2 ZOOM] touchpad to activate the zoom function. The cursor, which is redisplayed 3 sec before being erased, and the heading mark are shifted to the reciprocal bearing of the selected target (c), and the message "X2 ZOOM" flashes at the top right-hand side of the screen.

3. To cancel the zoom function, press the [X2 ZOOM] touchpad. The zoom function can also be cancelled by pressing the [SHIFT] touchpad.

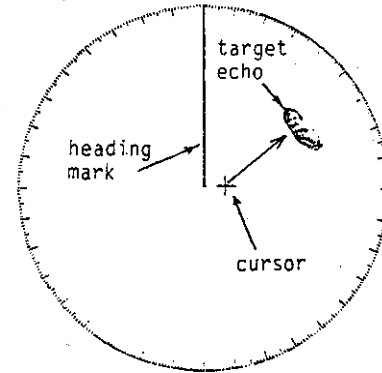

(a)

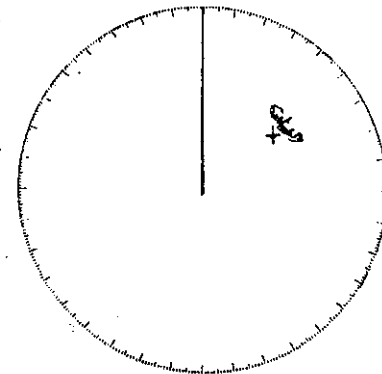

(b)

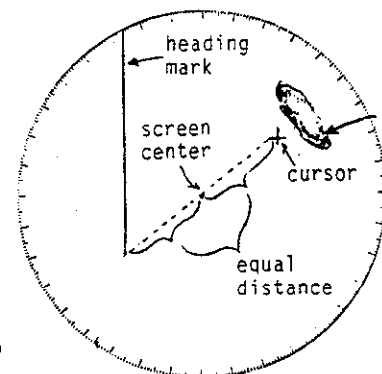

(c)

Fig. 1-13 Using the Zoom Function

TARGET PLOTTING

ECHO TRAIL

The [ECHO TRAIL] touchpad is used to plot the relative movement of targets to own ship. (True motion plotting is available when this radar is connected to the RP-1 Video Plotter and GC-1 Gyro Converter.) Each time the [ECHO TRAIL] touchpad is pressed the plotting time changes in the following sequence.

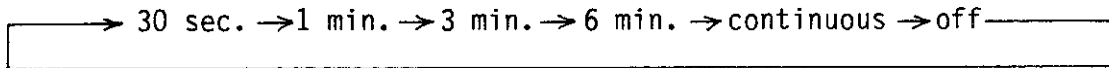

To change the plotting time indication, press the touchpad successively (no pause between presses).

When the plotting function is turned on (for example, 30 sec. is selected) the trail of every target starts extending and the on-screen timer starts counting up.

As soon as the timer counts 30 sec., the timer indication disappears and thereafter only plotting is continued. The trail of the target is erased from its oldest tip and only the last 30 sec. remains on the screen. The faster the speed of the target (relative to own ship), the longer the trail of the target.

NOTE: If continuous plotting is selected, the timer continuously exists on the screen, and it counts up from 0:00 to 99:59 and the trail extends continuously without being erased.

If the range or presentation mode is changed while plotting is being performed, the elapsed time or plot time is displayed inversely (black characters, green background), informing the operator that the plotting mode is suspended. Return to the previous range setting/presentation mode to resume plotting.

To erase the traces, press the [ECHO TRAIL] touchpad 10 seconds after the previous press.

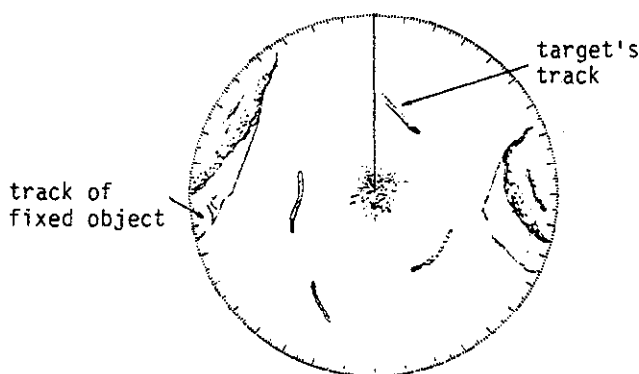
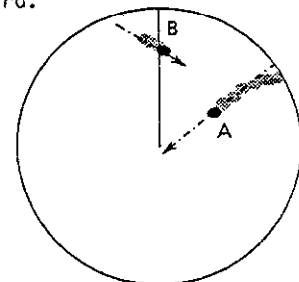

Fig. 1-14 Target Plotting

COLLISION COURSE?

To ascertain another ship as a hazardous target place the EBL on it. If the extension of the latest track is on it, it may be a hazardous one.

In the illustration below, ship A may be on a collision course while ship B will pass clear to starboard.



ECHO AVERAGING



The [ECHO AVG] touchpad is used to suppress sea clutter.

Echoes received from stable targets such as other ships (not moving at a fast relative speed to own ship) appear on the screen at almost the same position for every rotation of the sweep. On the other hand, unstable echoes such as sea clutter appear at random, sometimes making discrimination of target echoes difficult.

To distinguish target echoes from sea clutter, this radar uses the scan-to-scan correlation method. The scan-to-scan correlation method stores and averages successive picture frames. If the echo is stable it is presented in its actual strength level. And if it is unstable it is suppressed in brilliance, allowing you to discriminate targets from sea clutter.

To properly use the echo averaging facility, it is recommended to first suppress sea clutter with the A/C RAIN control (A/C SEA control: min.). Then, press the [ECHO AVG] touchpad. There are two levels of correlation, corresponding to the number of picture frames to be correlated, and the level in use is shown at the lower right-hand corner of the screen. Each time the touchpad is depressed the level of suppression changes in the following sequence.

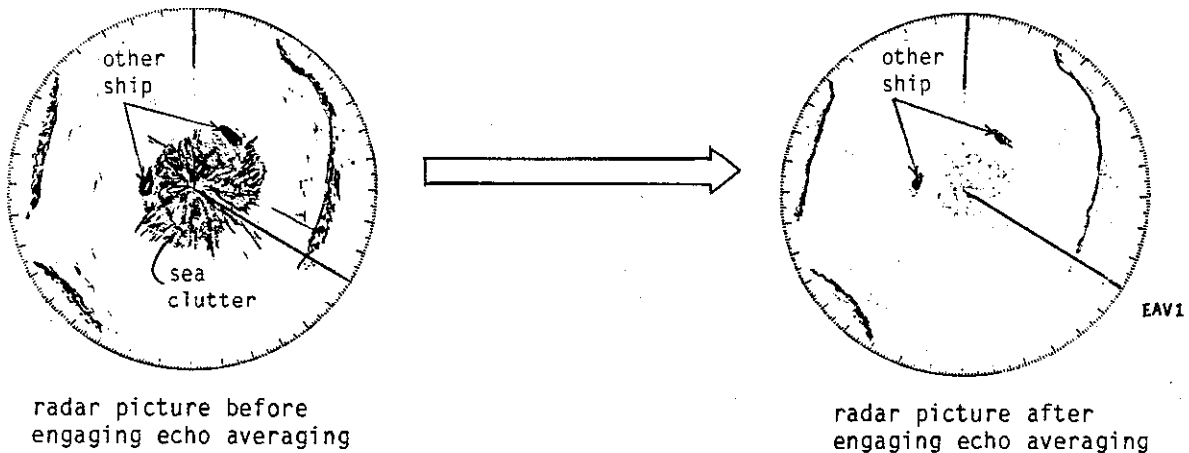
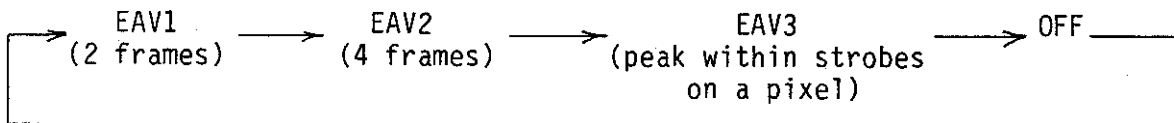

Fig. 1-15 Echo Averaging Function

Level EAV3 does not provide correlation but picks up the peak level among several strobos in a frame. This level is useful for tracking a target echo masked by short-range sea clutter.

NOTE: Echo average 1 & 2 should not be used under the following conditions.

- speed difference between own ship and other ships is large
- in Head-up Mode (EAV 3 may be used in the Head-up Mode)
- own ship is subjected to heavy pitching and rolling

SETTING THE ALARM



An alarm may be set to sound should targets (ships, landmasses, etc.) above a certain signal level enter into a preset guard zone. A guard zone is defined as an area within which you do not want targets to enter. The size of the guard zone may be set between 0 and maximum range for distance and between 0 and 360° in bearing.

This alarm is very effective as an anti-collision aid when using an autopilot or navigating in narrow channels. However, it does not relieve the operator of the responsibility to watch out for possible collision situations. It should never be used as a primary means to detect possible collision situations.

The procedure to set the guard zone and alarm is as follows.

For regular-type version

Range Setting

1. Press the ON portion of the [VRM] touchpad to display VRM1; and then rotate the VRM rotary knob control until VRM1 is at the range desired for the inner limit of the alarm.
2. Press the ON portion of the [VRM] touchpad to display VRM2; rotate the VRM rotary knob control until VRM2 is at the range desired for the outer limit of the alarm.

Sector Setting

3. Press the ON portion of the [EBL] touchpad to display EBL1; rotate the EBL rotary knob control until EBL1 is at the bearing desired for the counterclockwise limit of the alarm.
4. Press the ON portion of the [EBL] touchpad to display the EBL2; rotate the EBL rotary knob control until the EBL2 is at the bearing desired for the clockwise limit of the alarm.

Alarm Setting

5. Press the [GUARD ALARM] touchpad, and the indication "GUARD" will appear at the top right-hand side of the screen. Any targets entering the guard zone will trigger the alarm. The EBLs and VRMs may be operated without disturbing the settings of the alarm.

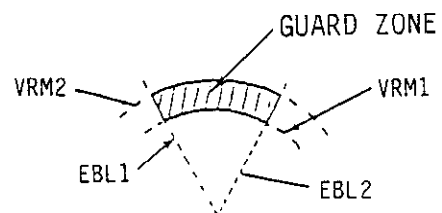

Fig. 1-16 Guard Zone

Should the alarm sound, press the [GUARD ALARM] touchpad once to silence it. The color of the letters and background of the message "GUARD" is

reversed; black letters, green background. To cancel the alarm, press and hold the touchpad for more than 1 sec.

NOTE 1: When the range in use is lower than the range of the guard zone, the indication "GUARD UP RANGE" appears on the screen, replacing the indication "GUARD."

NOTE 2: The alarm sounds when targets having a certain level of strength enter the guard zone. This level includes not only ships and landmasses, but also returns from seafloor or precipitation. Since the level is changeable with the environment, the operator is required to properly adjust the gain and anti-clutter controls.

For N-type version

1. Press the G-ZONE SET touchpad to enter the guard zone setting mode.
2. Press the VRM touchpad to display VRM; and then adjust the VRM control to set the outer margin of the guard zone. If you set the VRM reading to above 6 miles, the outer margin will be set to 6 miles ... maximum limit. If the VRM reading is set to less than 3.5 miles or VRM is not displayed (VRM off), the inner margin of the guard zone will be set to 3 miles ... minimum limit.
3. Press the EBL ON touchpad if the EBL is not displayed; and then adjust the EBL control to set the left margin of the guard zone. Press the EBL ON touchpad again to display the 2nd EBL which is indicated by long dash line. Adjust the EBL control to set the right margin of the guard zone. (EBL readout for the 2nd EBL is displayed below the 1st EBL readout.)
Thereafter, each time the EBL ON touchpad is pressed, the valid EBL changes between 1st and 2nd EBL's.
If the sector margin is not set (that is, no EBL displayed), the guard zone will be of circle (doughnut-shaped appearance).
4. Press the G-ZONE SET touchpad. The annunciator "GUARD" is displayed at upper right corner of the screen.
5. Should the alarm sound it can be stopped by pressing the ACKN touchpad. Press the touchpad again to reactivate the alarm.
6. To change or erase the guard zone, keep the G-ZONE SET touchpad pressed for more than 1 second.

reversed; black letters, green background. To cancel the alarm, press and hold the touchpad for more than 1 sec.

NOTE 1: When the range in use is lower than the range of the guard zone, the indication "GUARD UP RANGE" appears on the screen, replacing the indication "GUARD."

NOTE 2: The alarm sounds when targets having a certain level of strength enter the guard zone. This level includes not only ships and landmasses, but also returns from seafloor or precipitation. Since the level is changeable with the environment, the operator is required to properly adjust the gain and anti-clutter controls.

MAGNIFYING TARGET ECHOES

On longer ranges the echoes of targets are displayed only as small pips, making them difficult to see. To magnify the size of small targets on the 1.5nm range (middle 1 pulselength "M1P") or higher, press the [ECHO STRETCH] touchpad. "ESR" is displayed at the upper right-hand corner of the screen when the echo stretch function is on. The echo stretch function cannot be activated when in short ranges. "ESR" is displayed in black letters, green background if the touchpad is pressed when the range in use is less than 1.5nm, provided that the short pulselength is selected.

For log amplifier spec

Besides the above mentioned facility, by pulling out the A/C RAIN control knob (FTC ON), the short range targets can be enhanced and discrimination between large and small targets becomes easier. Note that the legend "FTC" is not displayed on the screen.

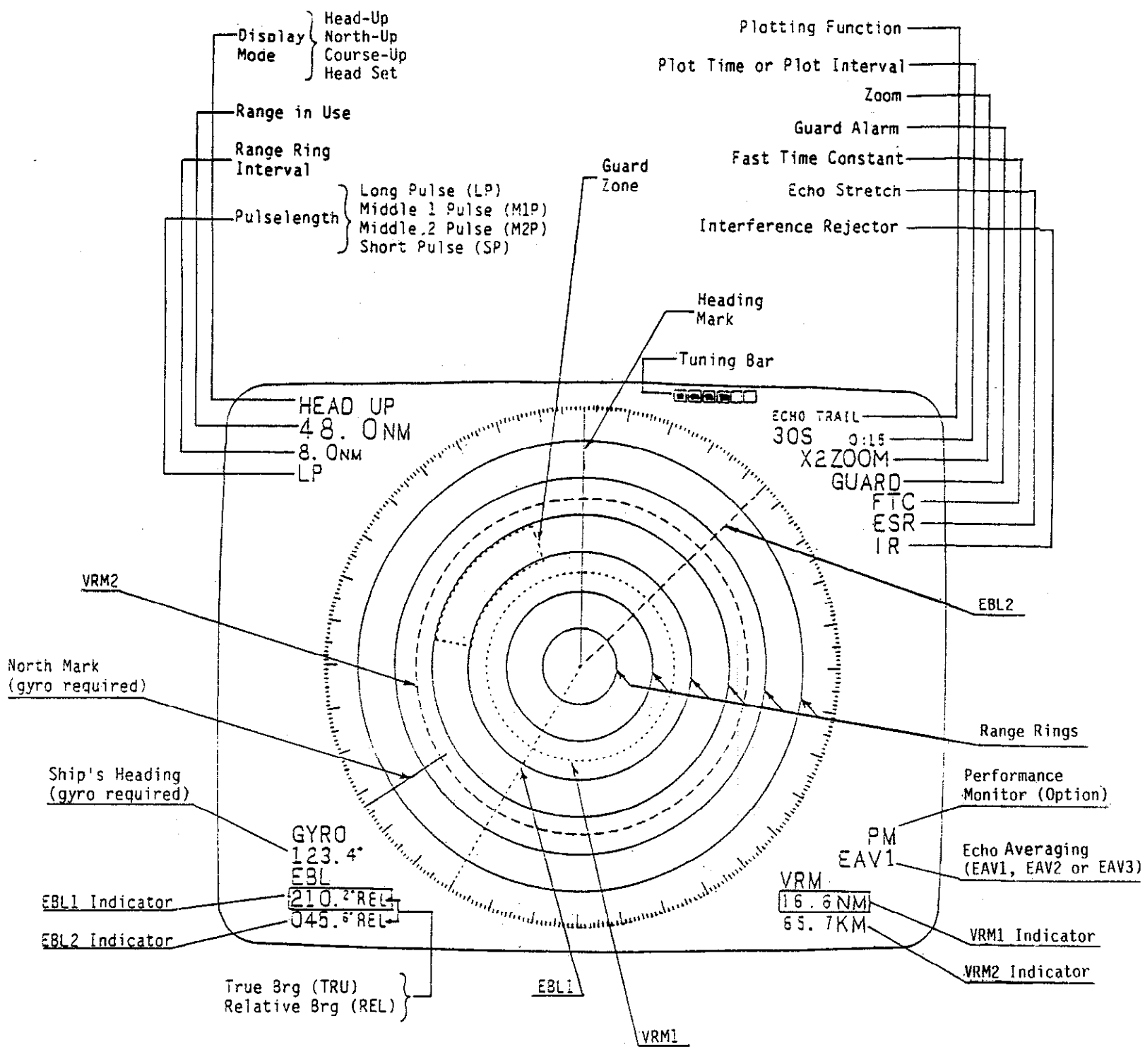

DISPLAY SCREEN INDICATORS

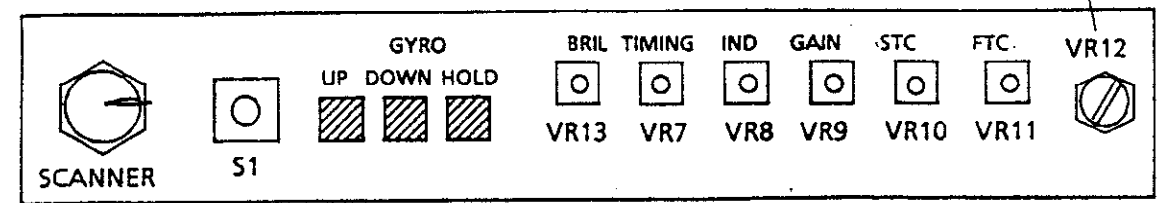

PRESET COMPARTMENT

Fig.1-17 Display Screen Indicators and Front Panel Operating Controls (Regular type version)

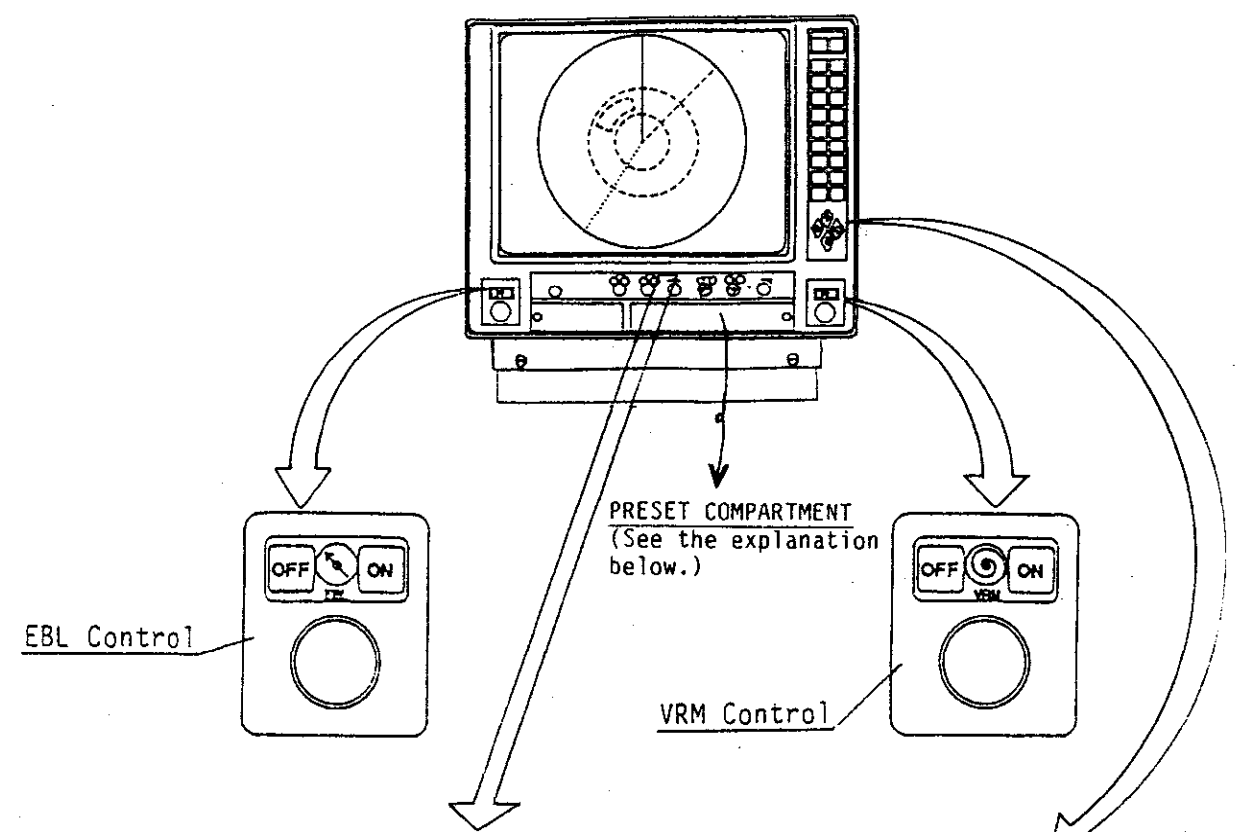

	Power Switch
	Panel Dimmer Control
	CRT Brilliance Control
	Tune Control
	A/C RAIN/FTC Control
	A/C SEA Control
	Gain Control

SUB OPERATING PANEL

	Range Control		STBY/TX Touchpad
	Pulselength Touchpad		Mode Touchpad
	Display Shift Touchpad		Heading Mark OFF Touchpad
	Range Ring Touchpad		Heading Mark Brill. Touchpad
	Mark Brilliance Touchpad		Int. Rej. Touchpad
	Perf. Monitor Touchpad		Echo Stretch Touchpad
	Guard Alarm Touchpad		Echo Trail Touchpad
	Echo Average Touchpad		Cancel (*) Touchpad
	Auto plot (*) Touchpad		X2 Zoom Touchpad
	Acquire (*) Touchpad		
	Cursor Shift Touchpads		

TOUCHPAD PANEL

(*) These touchpads are used only when optional equipments are connected.

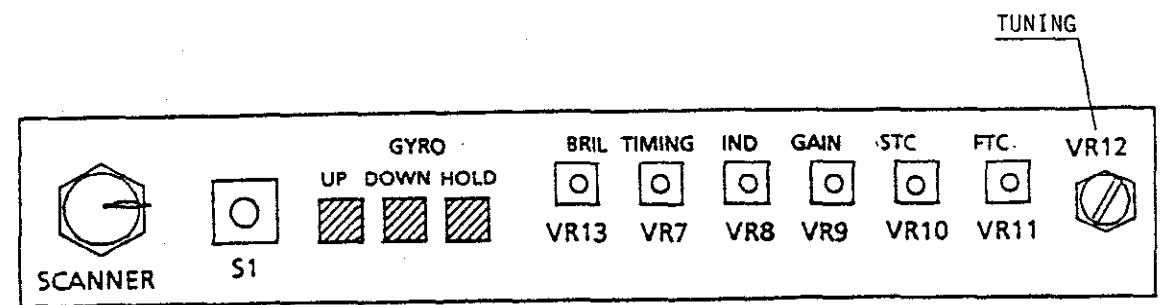
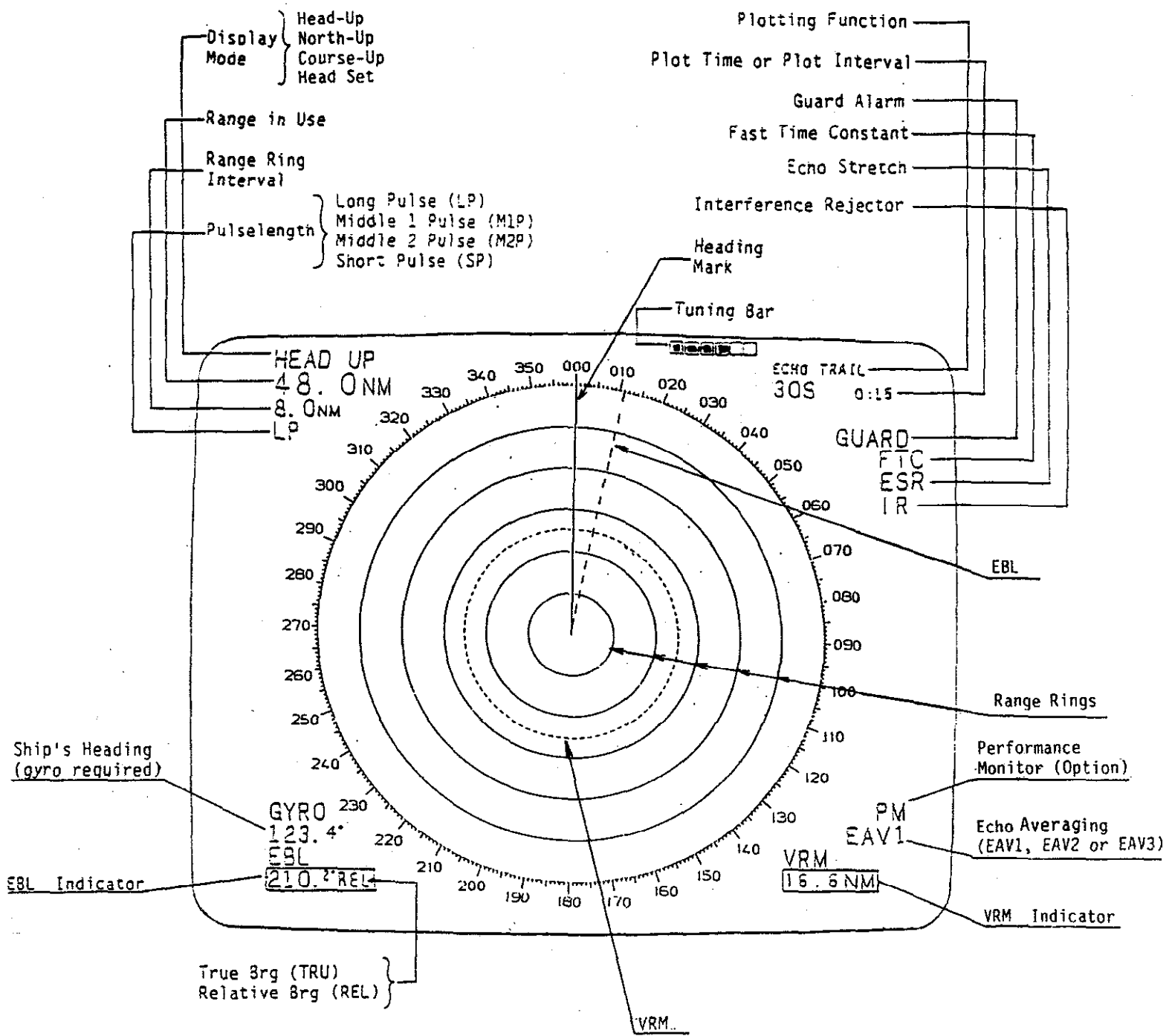

PRESET COMPARTMENT

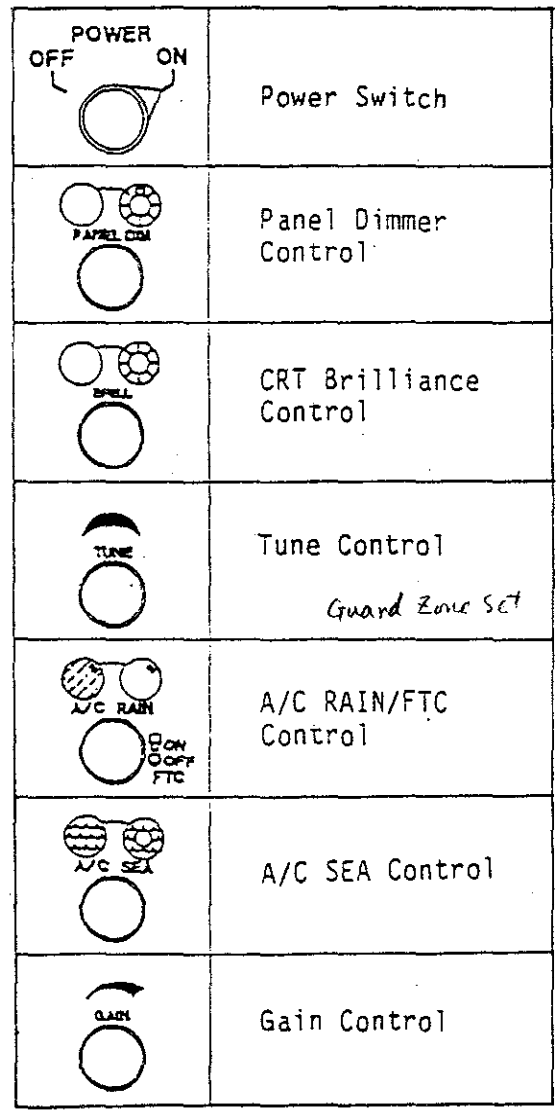

SUB OPERATING PANEL

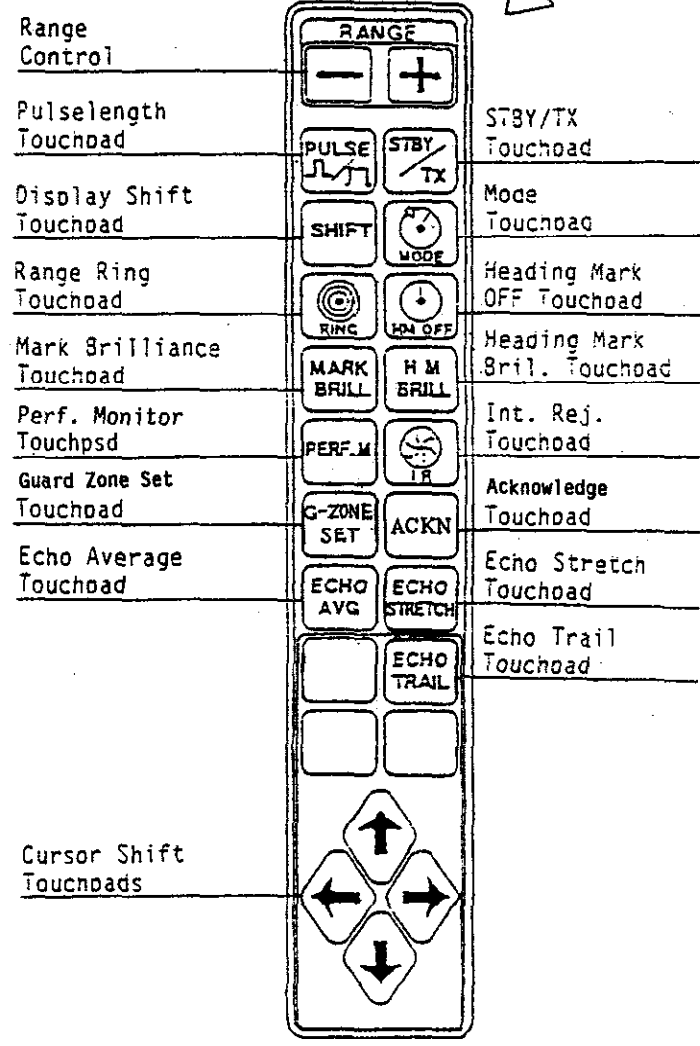
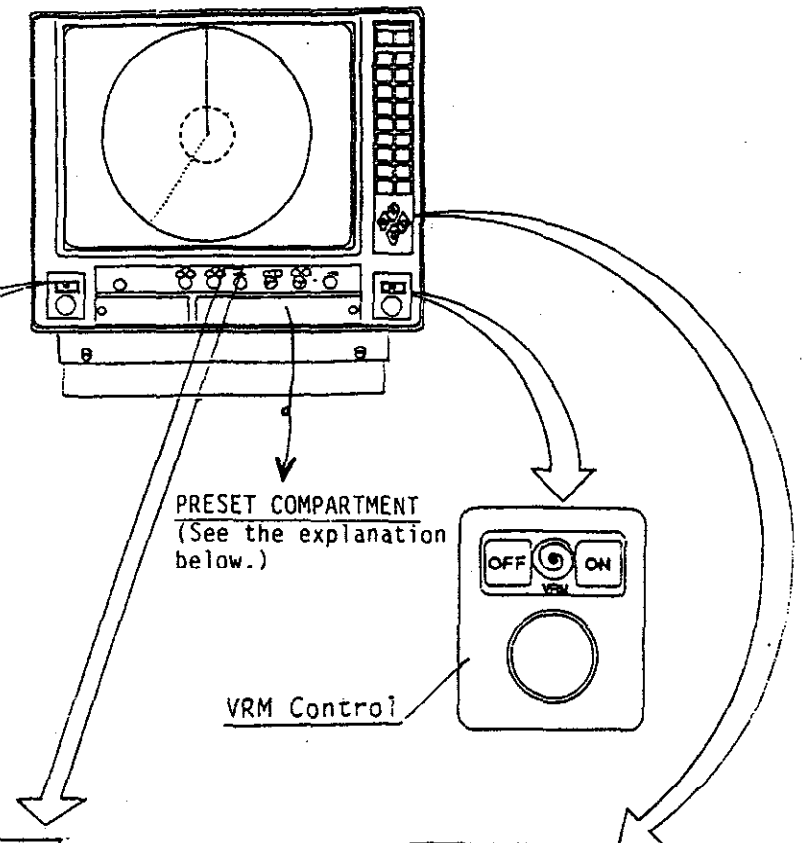

TOUCHPAD PANEL

Fig.1-18 Display Screen Indicators and Front Panel Operating Controls (N-type version)

(*) These touchpads are used only when optional equipments are connected.

CHAPTER 2 APPLICATION

In this chapter, minimum and maximum ranges, radar resolution, range measurement, false echoes and radar plotting will be discussed.

MINIMUM AND MAXIMUM RANGES**Minimum Range**

When the radar is used as a collision avoidance aid, the minimum detection range is of urgent concern. It is very dangerous for a target to disappear when it approaches the ship. The minimum range is primarily determined by the height of the antenna (vertical beam width of antenna) above the waterline.

Maximum Range

The maximum detecting range of the radar, R_{max} , varies considerably depending upon several factors such as the height of the antenna above the waterline, the height of the target above the sea, the size, shape and material of the target, and the atmospheric conditions.

Under normal atmospheric conditions, the maximum range is equal to the radar horizon or a little shorter. The radar horizon is longer than the optical one by about 6% because of the diffraction property of the radar signal. The R_{max} is given in the following equation.

$$R_{max} = 2.2 \times (\sqrt{h_1} + \sqrt{h_2})$$

where R_{max} : radar horizon (nm)
 h_1 : antenna height (m)
 h_2 : target height (m)

For example, if the height of the antenna above the waterline is 9 meters and the height of the target is 16 meters, the maximum radar range is:

$$R_{max} = 2.2 \times (\sqrt{9} + \sqrt{16}) = 2.2 \times (3 + 4) = 15.4 \text{ nm}$$

RADAR RESOLUTION**Bearing Resolution**

Bearing resolution is the ability to display as separate pips the echoes received from two targets which are at the same range and close together. It is proportional to the antenna length and reciprocally proportional to the wavelength. The length of the antenna radiator should be chosen for a bearing resolution better than 2.5° (International Maritime Organization (IMO) Resolution). This condition is normally satisfied with a radiator larger than 1.2 m (4 ft).

Range Resolution

Range resolution is the ability to display as separate pips the echoes received from two targets which are on the same bearing and close to each other. This is determined by pulselength only. The usual discrimination range is 22.8 m (25 yd) on a 0.08 microsecond pulse.

BEARING ACCURACY

One of the most important features of the radar is how accurately the bearing of the target can be measured. The accuracy of bearing measurement basically depends on the narrowness of the radar beam. However, the bearing is usually taken relative to the ship's heading, and thus, proper adjustment of the heading marker at installation is an important factor in ensuring bearing accuracy. To minimize error when measuring the bearing of a target, put the target echo at the extreme position on the screen by selecting a suitable range.

RANGE MEASUREMENT

Measurement of the range to a target is also a very important function of the radar. Generally, there are two means of measuring range: the fixed range rings and the variable range marker (VRM). The fixed range rings appear on the screen with a predetermined interval and provide a rough estimate of the range to a target. The variable range marker's diameter is increased or decreased so that the marker touches the inner edge of the target, allowing the operator to obtain more accurate range measurements.

FALSE ECHOES

Occasionally echo signals appear on the screen at positions where there is no target or disappear even if there are targets. They are, however, recognized if you understand the reason why they are displayed. Typical false echoes are shown below.

Multiple Echoes

Multiple echoes occur when a short range, strong echo is received from a ship, bridge, or breakwater. A second, a third or more echoes may be observed on the display at double, triple or other multiples of the actual range of the target as shown in Fig. 2-1. Multiple reflection echoes can be reduced and often removed by decreasing the gain or properly adjusting the A/C SEA control.

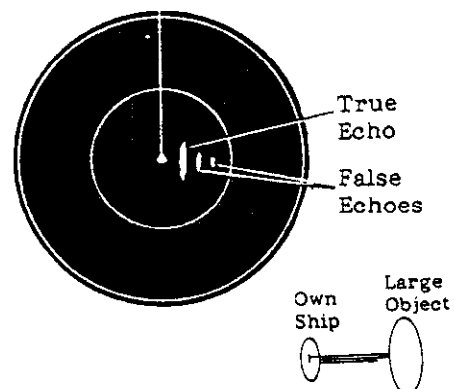

Fig. 2-1 Multiple Echoes

Side-lobe Echoes

Every time the radar pulse is transmitted, some radiation escapes on each side of the beam--called "side-lobes." If a target exists where it can be detected by the side lobes as well as the main lobe, the side echoes may be represented on both sides of the true echo at the same range, as shown in Fig. 2-2. Side lobes show usually only on short ranges and from strong targets. They can be reduced through careful reduction of the gain or proper adjustment of the A/C SEA control.

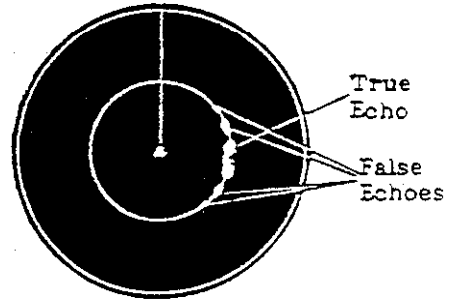

Fig. 2-2 Side-Lobe Echoes

Blind and Shadow Sectors

Funnels, stacks, masts, or derricks in the path of antenna may reduce the intensity of the radar beam. If the angle subtended at the scanner is more than a few degrees, a blind sector may be produced. Within the blind sector small targets at close and long ranges may not be detected. See Fig. 2-3.

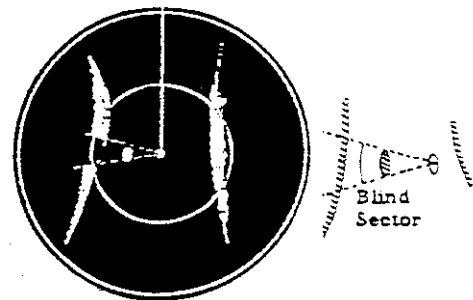

Fig. 2-3 Blind and Shadow Sectors

Virtual Image

A relatively large target close to your ship may be represented at two positions on the screen. One of them is the true echo directly reflected by the target and the other is a false echo which is caused by the mirror effect of a large object on or close to your ship as shown in Fig. 2-4. If your ship comes close to a large metallic bridge, for example, such a false echo may temporarily be seen on the screen.

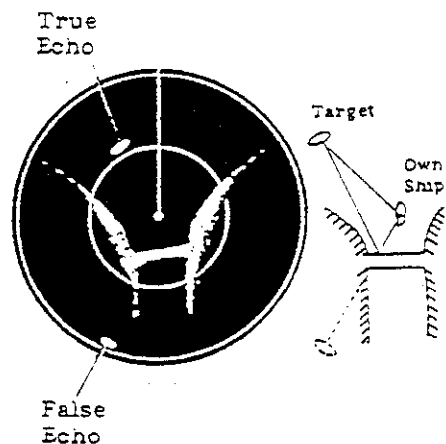

Fig. 2-4 Virtual Image

POSITION FIXING WITH RADAR

Radar Range

The simultaneous measurement of the ranges to two or more fixed objects is normally the most accurate method of obtaining a fix with radar alone. Preferably at least three ranges should be used. However the use of more than three range arcs may introduce excessive error because of the time lag between measurements, i.e., you will be moving as you take successive measurements.

When obtaining a fix, it is best to measure the most rapidly changing range last because of a smaller time lag in the radar plot from the ship's actual position. For greater accuracy, the objects selected should provide arcs with angles of cut as close to 90° as possible. Small, isolated, radar-conspicuous fixed objects whose associated range arcs intersect at angles approaching 90° provide the most reliable and accurate position fixes. Objects at longer ranges are less accurate for position fixing because they may be below the radar horizon and because the width of the radar beam increases with range.

To fix your position, first measure the range to two or more prominent navigational marks which you can identify on the chart. (The method for measuring range is given on page 1-8.) Next, with a compass sweep out the ranges from the charted positions. The point of intersection of the arcs is your estimated position. The method to obtain a position fix using radar range is illustrated in Fig. 2-5.

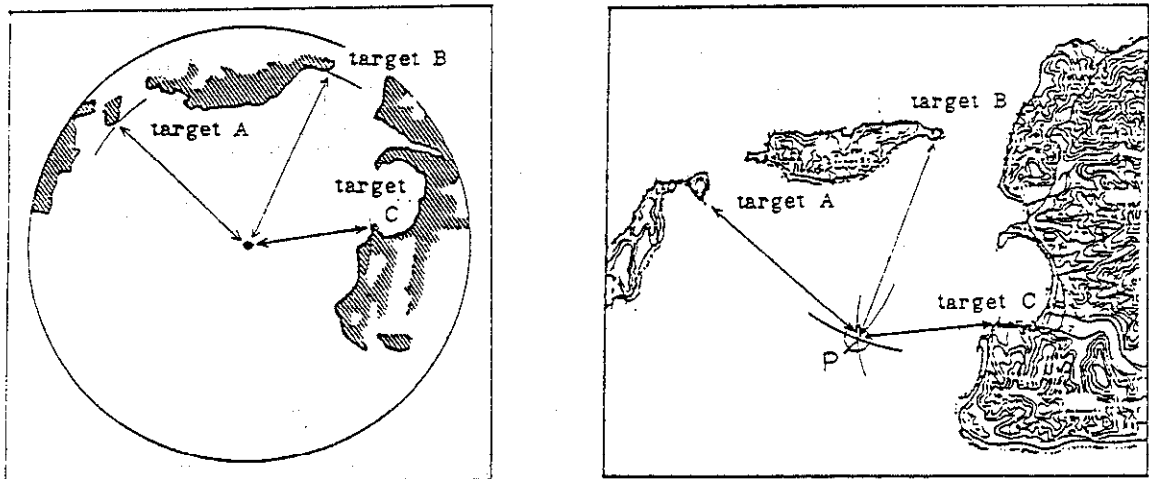

Fig. 2-5 Position Fixing Using Range

Range and Bearing

The advantage of position fixing by range and bearing is the speed with which a fix can be obtained. A distinct disadvantage however is that this method is based upon only two intersecting position lines, a bearing line and range, obtained from two points of land. If possible, the object used should be small, isolated and identified with reasonable certainty. To fix

your position using range and radar bearing, measure the relative bearing of the target with the EBL, noting the exact direction of the ship's heading when doing so. Next, make allowance for compass deviation (true or magnetic) and find the true bearing of the target. Sweep out the range to the target with a compass on the chart and plot the true bearing of the target. The point of intersection is your approximate position. Fig. 2-6 illustrates how to obtain a position fix using range and bearing.

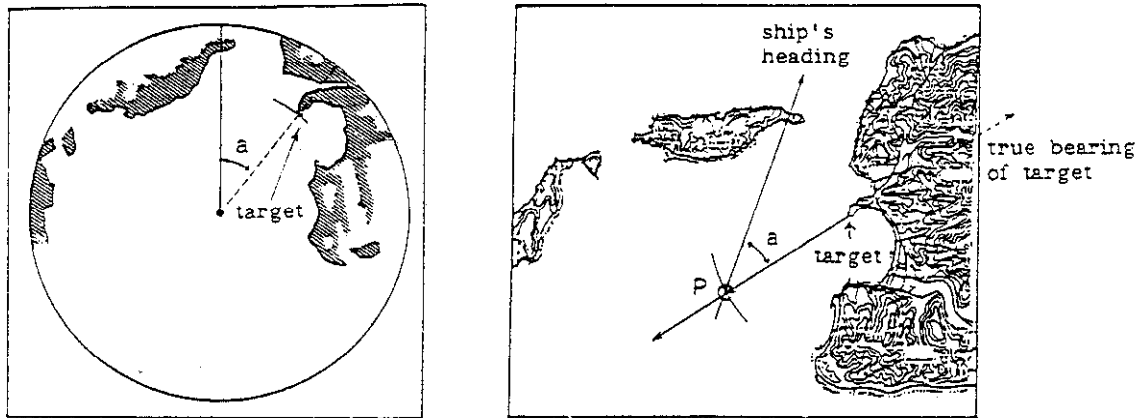

Fig. 2-6 Position Fixing Using Range and Bearing

Two Bearings

Generally, fixes obtained from radar bearing are less accurate than those obtained from intersecting range arcs. The accuracy of fixing by this method is greater when the center bearings of small, isolated radar-conspicuous objects can be observed. Similar to position fixing using range and bearing, this method affords a quick means for initially determining approximate position. The position should then be checked against other means to confirm reliability.

Position fixing using two bearings is determined by measuring the relative bearings for the two targets and then determining their true bearings. Plot the two bearings on the chart; the point of intersection of the two bearings is your approximate position. Fig. 2-7 illustrates how to obtain a position fix using two bearings.

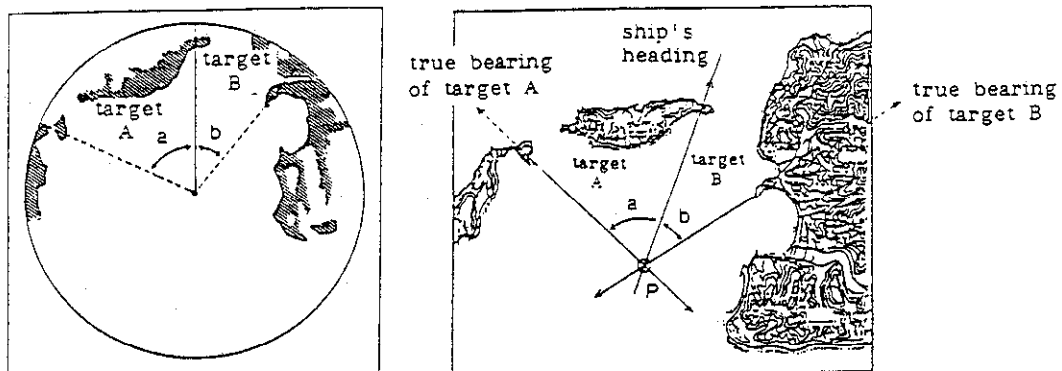

Fig. 2-7 Position Fixing Using Two Bearings

CHAPTER 3 MAINTENANCE

This radar is designed and constructed to give the user many years of trouble-free operation. However, to maintain optimum performance maintenance must be performed at regular intervals. Recommended maintenance intervals and check points are given in the table below.

"CAUTION"

Before beginning maintenance work, be sure to switch off the radar at the main switchboard. When checking inside the units, wait for a few minutes until the high voltage components (CRT or HV capacitors) can discharge the residual charge.

Interval	Check Point	Check/Measures	Remarks
3 to 6 months	Exposed nuts and bolts on scanner unit	Check for corroded or loosened nuts/bolts. If necessary, clean them and repaint thickly. Replace them if heavily corroded.	*Sealing compound may be used instead of paint. *Put slight amount of grease if nuts and bolts are replaced.
	Scanner radiator	Check for dirt or cracks on the radiator surface. Thick dirt should be wiped off by using a soft cloth immersed in fresh water. If a crack is found, apply a slight amount of sealing compound or adhesive as first-aid treatment, then call for repair.	*Do NOT use plastic solvent (thinners or acetone) for cleaning. *When removing ice on the scanner unit, use a wooden hammer or plastic-head hammer. Crack on the scanner unit may allow water to penetrate inside, causing permanent damage to the internal circuitry.
	Terminal boards and plugs in scanner unit	Open scanner cover to check terminal board/plug connections inside. Also check if the rubber packing of the scanner cover is in good order.	*When putting cover back in position, be careful not to catch flying wires between cover and unit.
	CRT screen	Dirt on this creates symptoms identical to poor sensitivity. Clean CRT surface carefully, using care not to scratch it.	*Use a soft cloth with a slight amount of anti-static-charge spray. Never apply plastic solvent.

Interval	Check Item	Check/Measures	Remarks
6 months to 1 year	Scanner motor (See Fig. 3-1.)	Check and clean carbon brushes and commutator. If brushes have worn out or abnormal spark is seen replace them.	*Under normal use, the carbon brush will last approximately 2000 hours.
	CRT anode and approach (See Fig. 3-2.)	High tension on CRT attracts dust in environment, and moist dust will cause poor insulation. Ask your dealer to clean high voltage parts. <u>Do not touch these parts.</u>	*If any crack is found on rubber cap or wire sheath, ask your dealer to replace damaged part.
	Terminal boards, sockets and plugs	Check for loose connections. Clean contacts or replace plug, if necessary.	

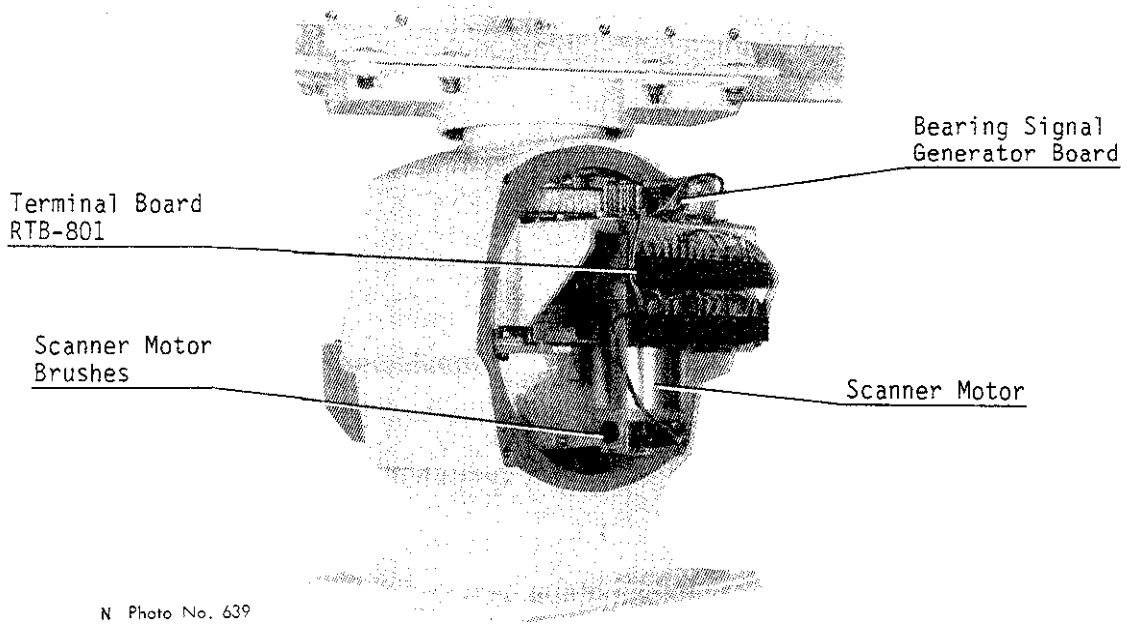

Fig. 3-1 Scanner Unit, Front Cover Removed

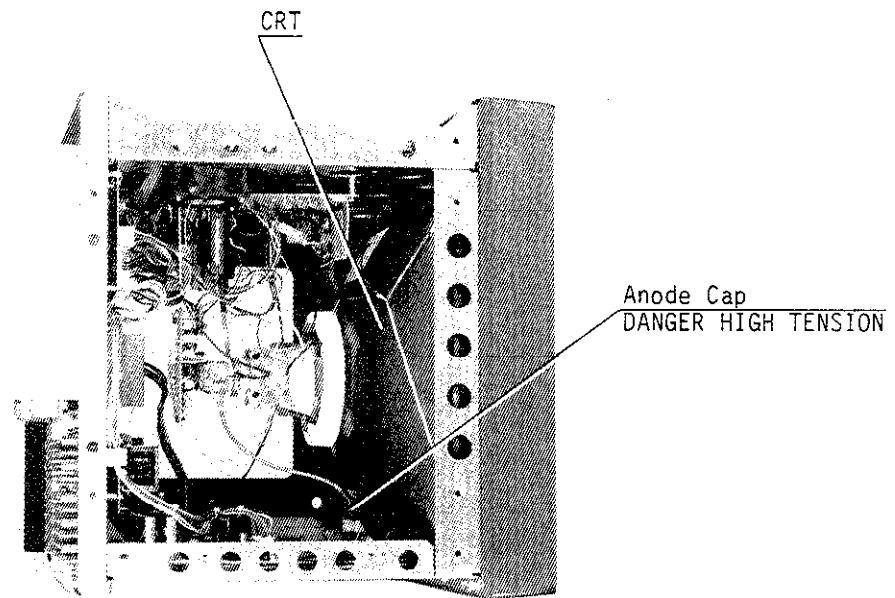

Fig. 3-2 Display Unit, Top View

CHAPTER 4 TROUBLESHOOTING

Whenever you suspect the radar is not functioning properly, turn it off and check plug connections on p.c. boards, then proceed to the Trouble Finding List on the next page, if necessary. If a board is found to be faulty, replace it or call for service. Do not attempt further component check in any p.c. board. Careless handling may damage the board.

"CAUTION"

There are many high tension points in the radar system. Take special care when approaching the following parts.

1. Power supply circuit (Display Unit)
2. CRT circuit (Display Unit)
3. Modulator circuit (Scanner Unit)
4. Magnetron (Scanner Unit)

Service Call

Please provide the following information when requesting service.

1. Name of the vessel
2. Vessel's location (port/berth)
3. Sailing Schedule
4. Radar model (Serial number/Date manufactured)
5. Description of the problem (include results of the troubleshooting checks)
6. Previous service

Trouble Finding List

Operation	Symptom	Check Point	Remarks
Turn Power on and adjust PANEL DIMMER control.	Illumination lamps for front panel do not come on with PANEL DIMMER turned fully CW.	<ol style="list-style-type: none"> 1. Main fuse F1351 (Display rear) See Fig. 4-1. 2. Mains voltage/polarity 3. POWER SUPPLY board 4. Illumination lamps 	<p>*Measure mains voltage at DTB-I #1(+) and #2(-). See Fig. 4-1. The voltage should be:</p> <p>10.2 to 15VDC (12VDC set)</p> <p>20.4 to 40VDC (24/32VDC set)</p>
	Scanner does not rotate.	<ol style="list-style-type: none"> 1. Scanner fuse F1352 (5A) See Fig. 4-1. 2. Scanner Motor brushes 3. Scanner rotating mechanism jammed 4. Power supply circuit for scanner motor 	<p>*If bearing pulse is not being sent from scanner, "NO BP" is displayed on the screen.</p>
Adjust BRILLIANCE control.	Nothing appears on CRT.	<ol style="list-style-type: none"> 1. CRT 2. CRT H.T. 	<p>*Visually check that CRT heater is lit.</p>

Continued

Operation	Symptom	Check Point	Remarks
		3. DEFLECTION board 4. PROCESSOR board	*Adjust SUB CONTRAST pot. (VR11) and BRIGHT SUB pot. (VR2) on DEFLECTION board. See Fig. 4-2. If picture appears, CRT assembly is OK.
	Picture synchronization is abnormal.	1. CRT assembly (DEFLECTION board, etc.) 2. PROCESSOR board	*Adjust H-HOLD pot. (VR41) on DEFLECTION board. See Fig. 4-2. If synchronization is not achieved, DEFLECTION board is defective.
After ST-BY message appears, press [STBY/TX] touchpad.	Marks and legends appear abnormally.	1. PROCESSOR board	
Adjust GAIN control with A/C SEA control set at minimum.	Marks and legends appear but no noise nor echo.	1. IF amplifier (Fig. 4-4) 2. Multicore cable between the scanner and display 3. PROCESSOR board	*Check continuity and isolation of coax. cable. (Note: Disconnect the plug and lugs at the both ends of coax. cable before checking it by ohmmeter.)

Continued

Operation	Symptom	Check Point	Remarks
	<p>Marks, legends and noise appear but no echo. (No transmission leak appears.)</p>	<ol style="list-style-type: none"> 1. TX fuse F1 (0.5A) See Fig.4-1. 2. Magnetron (Fig. 4-5) 3. MODULATOR board (Fig. 4-5) 4. MODULATOR TRIGGER board (Fig. 4-4) 5. Modulator SCR 6. PROCESSOR board 	<p>*If fuse is blown replace it. If it blows again, the magnetron or modulator's components may be faulty.</p> <p>*Connect a multimeter between pins TP1(+) and TP2(-) of "TEST" point on INTERFACE board and set the radar to transmit on 72 nm range. If the voltage is within 3 to 6VDC, 2 to 5 of "Check Point" may be OK.</p> <p>*Connect a multimeter set at 10VAC range between test points TX-TRIG (+) and GND (-) on PROCESSOR board. If the voltage reading changes when changing the range, the PROCESSOR board in the display unit are operating normally.</p>
	<p>Sweep rotation is not synchronized with antenna rotation.</p>	<ol style="list-style-type: none"> 1. BEARING SIGNAL GEN. board (Scanner unit) 2. PROCESSOR board 	
	<p>Abnormal bearing of picture</p>	<ol style="list-style-type: none"> 1. Adjustment of heading SW S1 in preset compartment. 2. PROCESSOR board 3. Gyro Interface board (option) 	<p>*The message "NO HP" appears on the screen when heading pulse is not received.</p>

Continued

Operation	Symptom	Check Point	Remarks
Adjust TUNE control.	Poor sensitivity	<ol style="list-style-type: none"> 1. Deteriorated Magnetron 2. Detuned MIC 3. Dirt on Radiator face 4. Water leak on waveguide 	*Set range to 72 nm and measure voltage between pins TP1(+) and TP2(-) of "TEST" point on INTERFACE board. If the voltage is too low, magnetron may be faulty. Refer to "Remarks" on page 4-4.
Pull FTC (A/C RAIN) control	No FTC effect.	<ol style="list-style-type: none"> 1. CONTROL PANEL board 2. PROCESSOR board 	
Adjust A/C RAIN control.	No A/C RAIN effect.	<ol style="list-style-type: none"> 1. CONTROL PANEL board 2. STC board 	
Change range.	Radar picture is not changed.	<ol style="list-style-type: none"> 1. CONTROL PANEL board 2. PROCESSOR board 	
Press [IR] touchpad.	Interference Rejection is not performed. ("IR" not displayed.)	<ol style="list-style-type: none"> 1. Bad contact of touchpad key 2. PROCESSOR board 	
Press [ECHO TRAIL] touchpad.	No Echo Trail function.	<ol style="list-style-type: none"> 1. Bad contact of touchpad key 2. PROCESSOR board 	

Continued

Operation	Symptom	Check Point	Remarks
Press [RING] touchpad.	No range ring	1. Bad contact of touchpad key 2. PROCESSOR board	

NOTE: If the touchpad keys other than mentioned above malfunction, first check the contact of the corresponding touchpad. If it is OK, PROCESSOR board may be faulty.

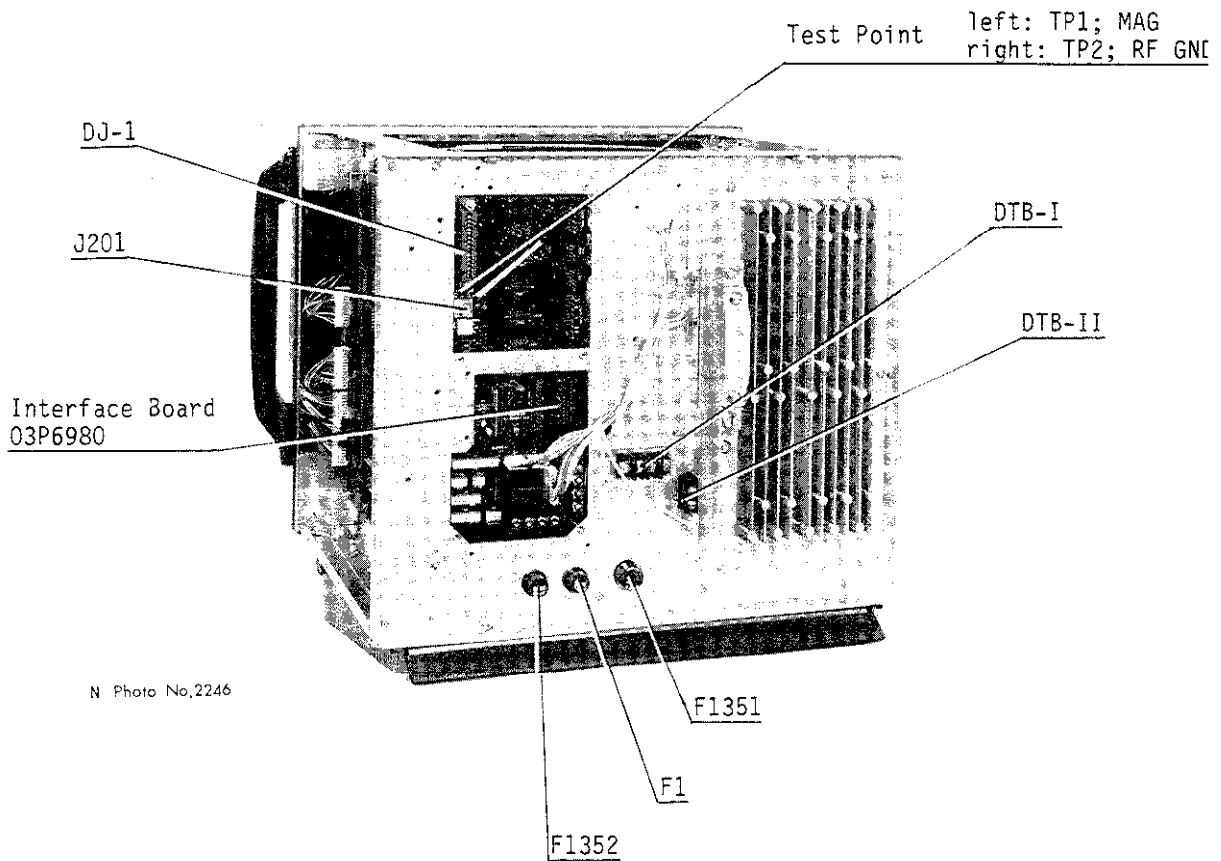
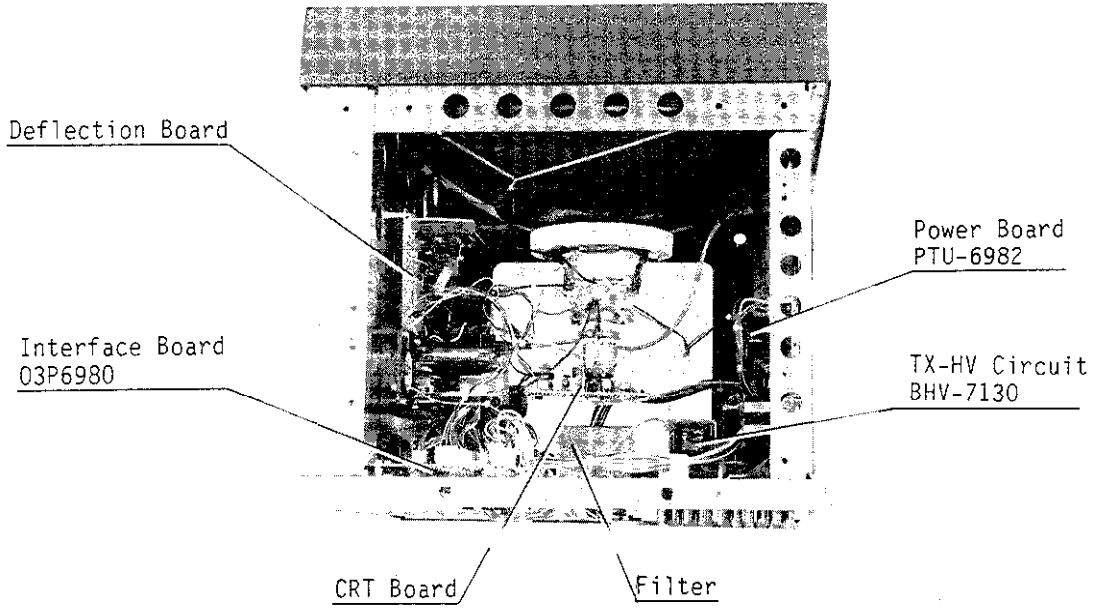
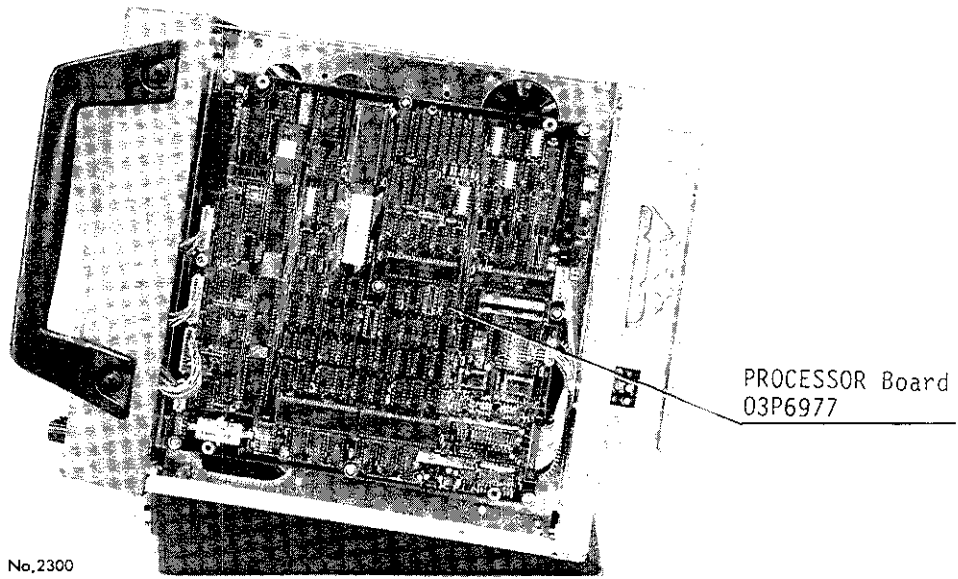

Fig. 4-1 Display Unit, Rear View



N Photo No.2247

Fig. 4-2 Display Unit, Top View



N Photo No.2300

Fig. 4-3 Display Unit, Right Side View

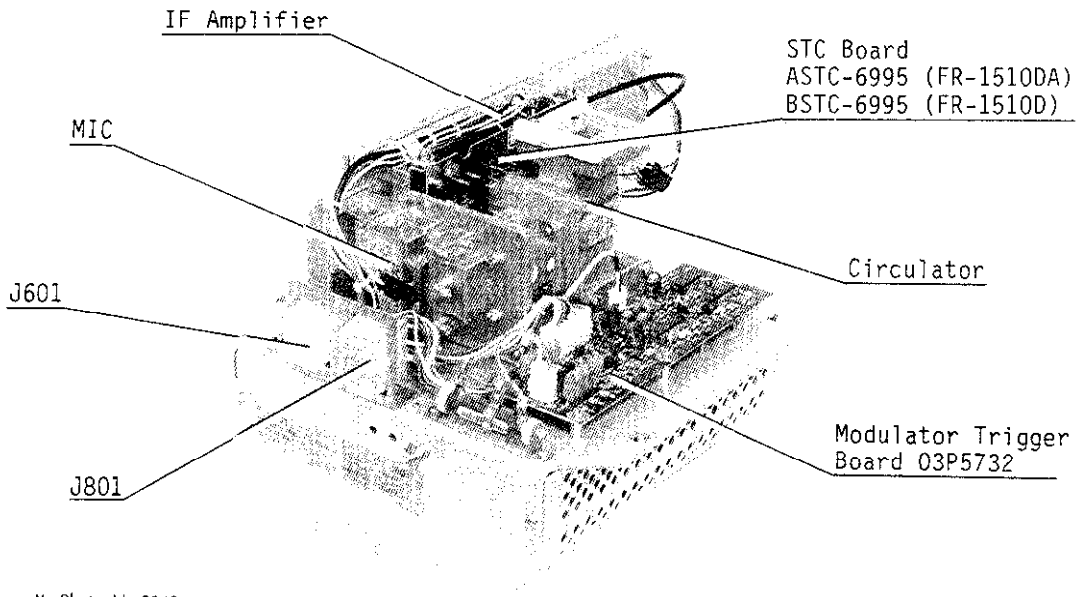

Fig. 4-4 Transceiver Module

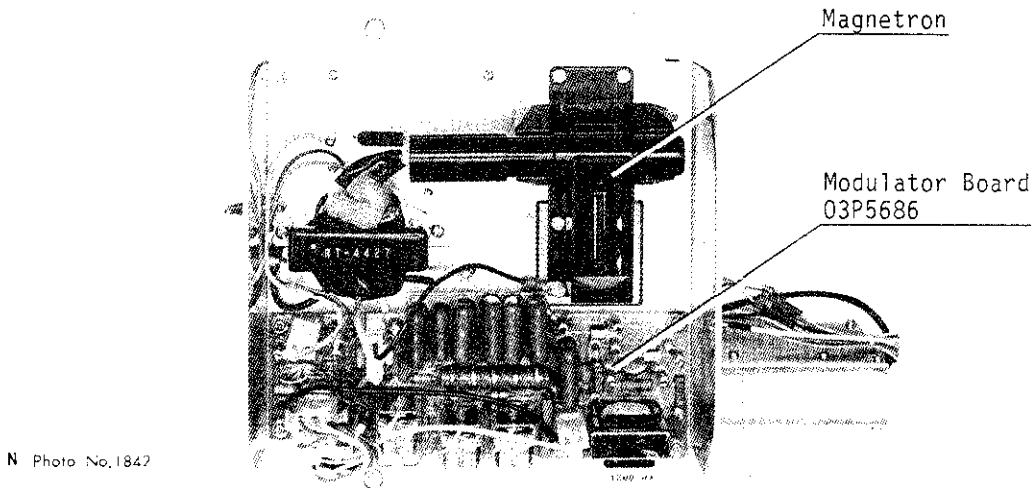

Fig. 4-5 Transceiver Module, Bottom View

CHAPTER 5 INSTALLATION**GENERAL**

This radar system is mainly composed of two units, the display unit and the scanner unit, and operates directly from the ship's mains of 12, 24 or 32VDC. For operation from 100, 110, 115 or 220VAC, a rectifier unit is required.

When the radar is first unpacked, check that all necessary units, parts and materials are contained, by referring to the equipment, installation materials and spare parts lists. All steel and wood works should be arranged locally.

SCANNER UNIT INSTALLATION**Siting Considerations**

The scanner unit is generally installed on top of the wheelhouse or on the radar mast on an appropriate platform. When siting the unit, consideration must be given to the following points.

- 1) The standard supply interconnecting cable RW-3839-2 run between the scanner unit and the display unit is 15m long. If additional cable is required for a particular installation an unbroken length must be used (i.e., no splices allowed), and the maximum length is 100 meters.
- 2) A funnel, mast or derrick post in line of sight of the radiator may cause blind sectors on the radar picture. A shadow sector between 355 and 5 degrees must be avoided by carefully planning the installation site.
- 3) Deposits and fumes from the funnel or other exhaust vent can adversely affect the aerial performance and hot gas tends to distort the radiator portion. The scanner unit must not be mounted in a place where it may be subjected to temperature in excess of 70°C.
- 4) The unit must not be positioned in close proximity to a direction finder (DF) aerial; separation of more than 2 meters is recommended.
- 5) The compass safe distance; 3.4 meters, standard compass, 2.2 meters, steering compass, should be observed.

Mounting and Connecting

Note the following cautions before beginning work on the scanner unit.

- 1) Do not lift the scanner unit by the radiator.
- 2) The seal washers and corrosion-proof rubber mat should be used to prevent electrolytic corrosion.

- 3) Run a grounding wire between the ground terminal fitted on the scanner bottom and the nearest ground spot as illustrated below.

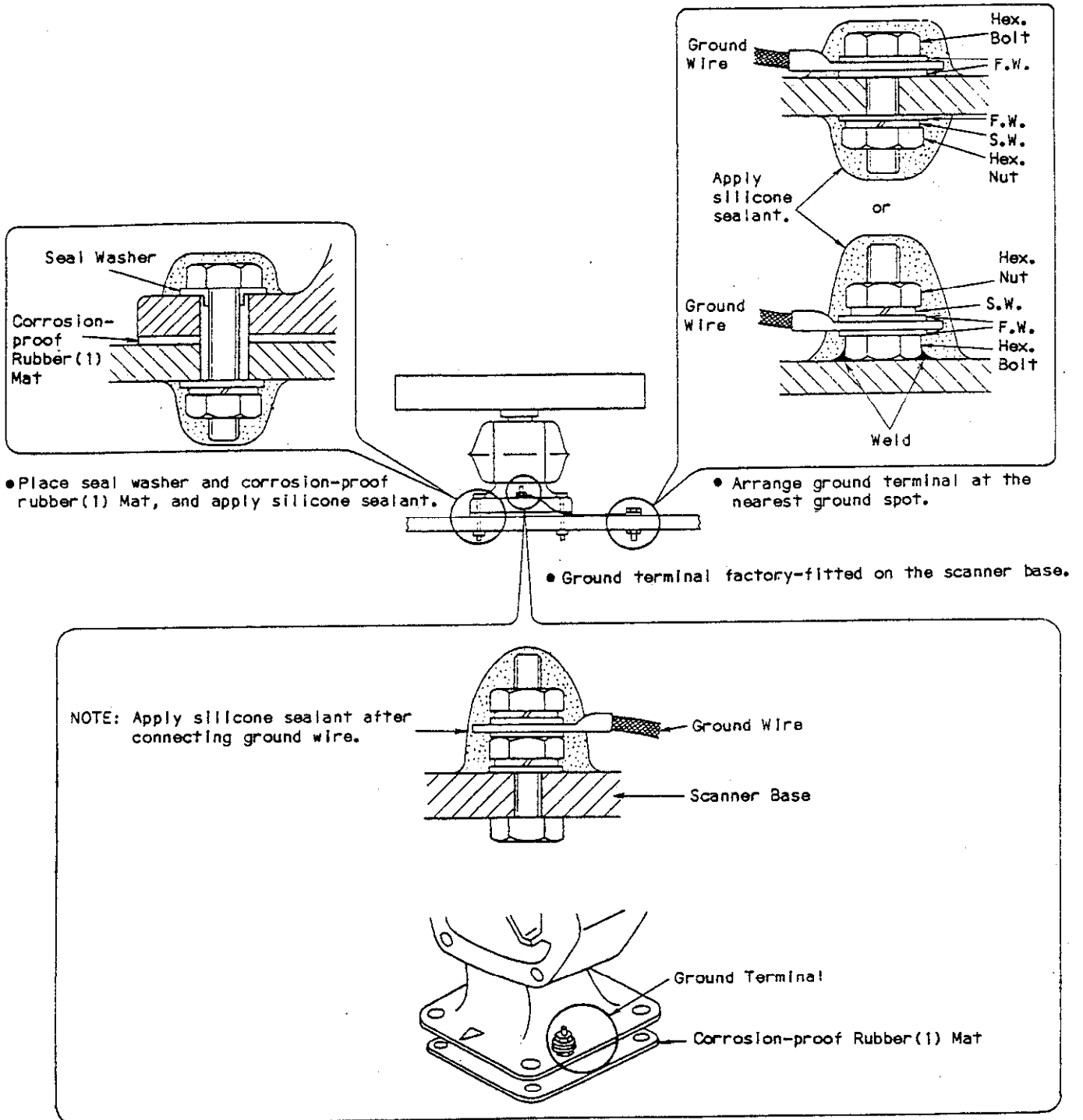

Fig. 5-1 Remarks on Installation of the Scanner Unit

- 4) Do not paint the radiator aperture.
- 5) Apply silicone sealant to bolts, nuts and washers to make future removal easier.

Fixing the Scanner Housing to the Chosen Site

1. Drill four bolt holes (15mm dia.) and one cable entry hole (approx. 50mm dia.) in the radar mast platform or the deck. See the scanner outline drawings on page 5-4 (XN-2/XN-3), or page 5-5 (XN-3A/XN-4A).
2. Place the corrosion-proof rubber mat on the chosen site.
3. Place the scanner on the mat and orientate the scanner so that the forward mark on the scanner base faces the ship's bow.
4. Insert the seal washers onto the bolts; apply silicone sealant over the bolts and nuts.
5. Fix the scanner to the chosen site, using the M12x60 bolts, nuts and washers supplied.

Connecting the Multicore Cable

Only the multicore cable runs to the scanner unit. The procedure for connecting the multicore cable to the scanner unit is as follows.

6. Pass the open end of the cable toward the scanner unit through a pipe or waterproof cable gland fitted through the top of the wheelhouse or bulkhead.
7. Open the scanner housing covers by removing the four bolts. Remove the transceiver fixing bolts and disconnect plugs P601 and P801; take out the transceiver module. See Fig.5-3 on page 5-6.

NOTE: To prevent magnetron demagnetization, do not place the transceiver module directly on a steel deck, etc. Place it on top of non-magnetic material (wood platform, styrofoam, etc.) or tilt it on its side as illustrated in the figure below.

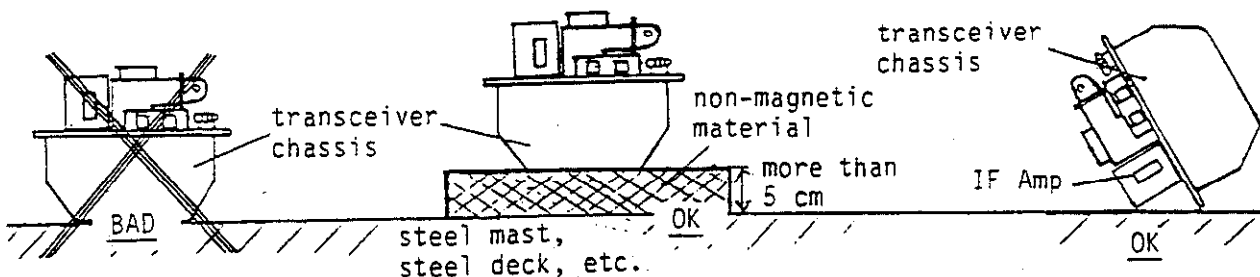
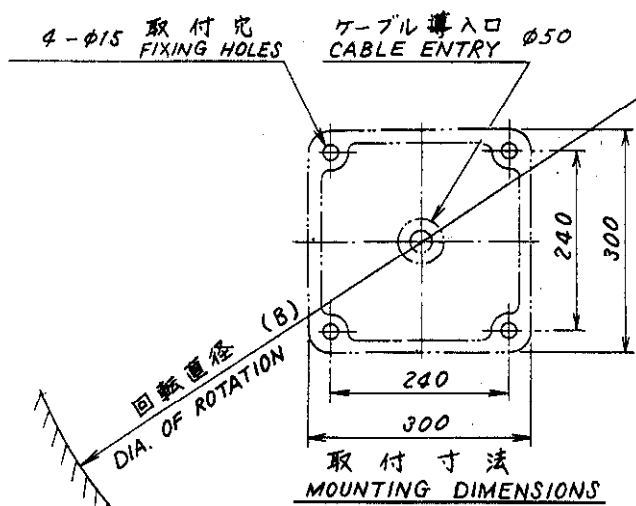
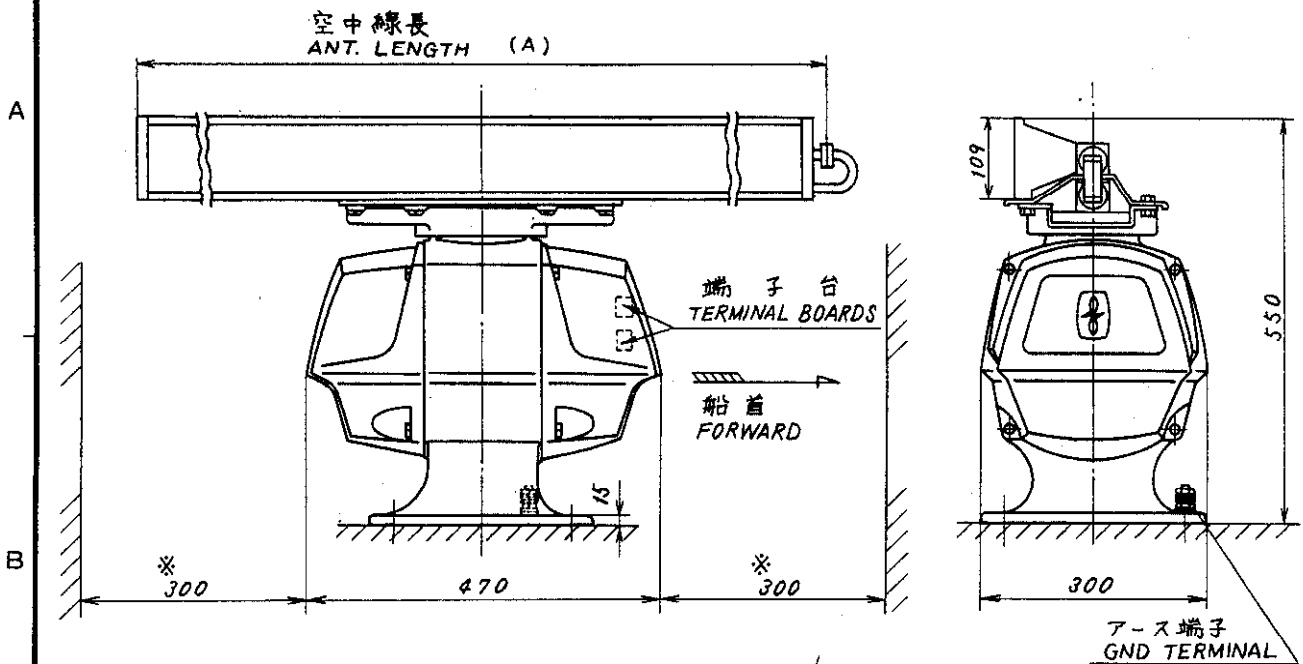

Fig. 5-2 Preventing Demagnetization of the Magnetron

8. Remove the cable gland at the bottom of the scanner housing.
9. Pass the multicore cable through the scanner base and the cable gland (removed in step 8). See Fig. 5-4.



NOTE 1. ※: 推奨サービス空間 RECOMMENDED SERVICING CLEARANCE.

NOTE 2.

種類※※ ANT. TYPE	90cm 型 TYPE	123cm 型 TYPE	200cm 型 TYPE
空中線長 (A) ANT. LENGTH	910mm	1250mm	2000mm
回転直径 DIA. OF (B) ROTATION	1100mm	1400mm	2200mm
重量 WEIGHT	32kg	33kg	37.5kg

※※ 選択可能な空中線部種類は、レーダー型式により異なる。各仕様を参照のこと。
SELECTABLE ANTENNA TYPE DEPENDS ON RADAR MODEL. SEE INDIVIDUAL SPECIFICATIONS.

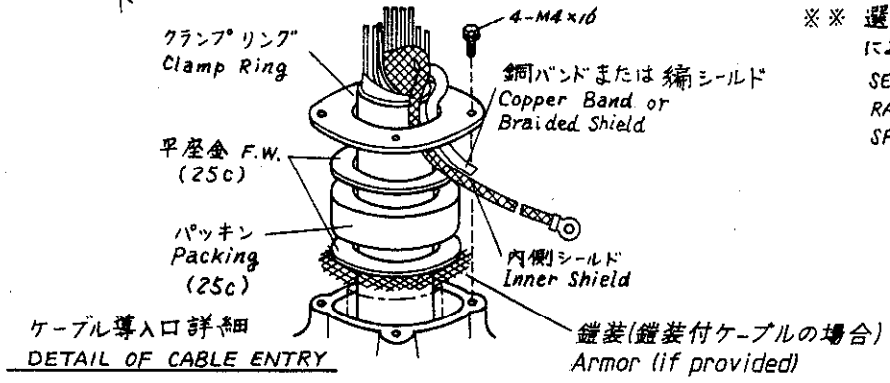

品番 ITEM	品名 NAME	材質 MATERIAL	数量 Q'TY	図番 DWG. NO.	摘要 REMARKS
承認 APPROVED	三角法 THIRD ANGLE PROJECTION	名称 TITLE	空中線部外寸図 SCANNER UNIT		
検図 CHECKED	尺度 SCALE	XN1/2/3-C2P7N2N/C2P8N2N/RSB-0063			
製図 DRAWN	重量 WEIGHT	kg	図番 DWG. NO.	C3237-001-S	

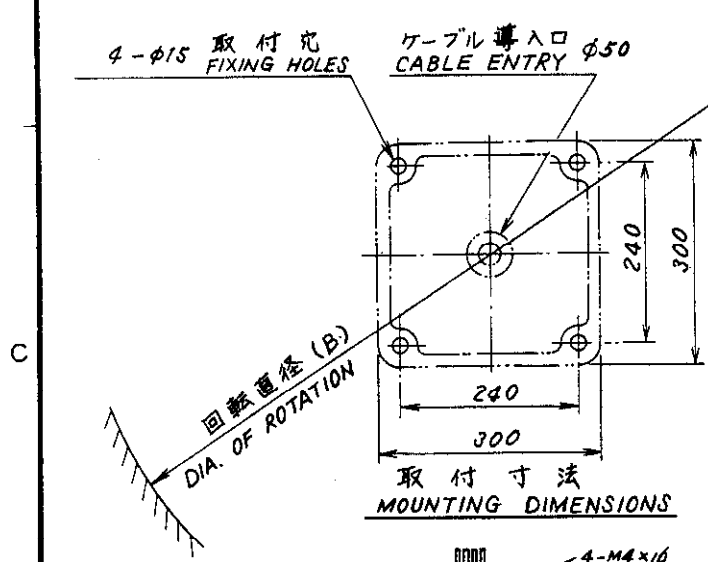
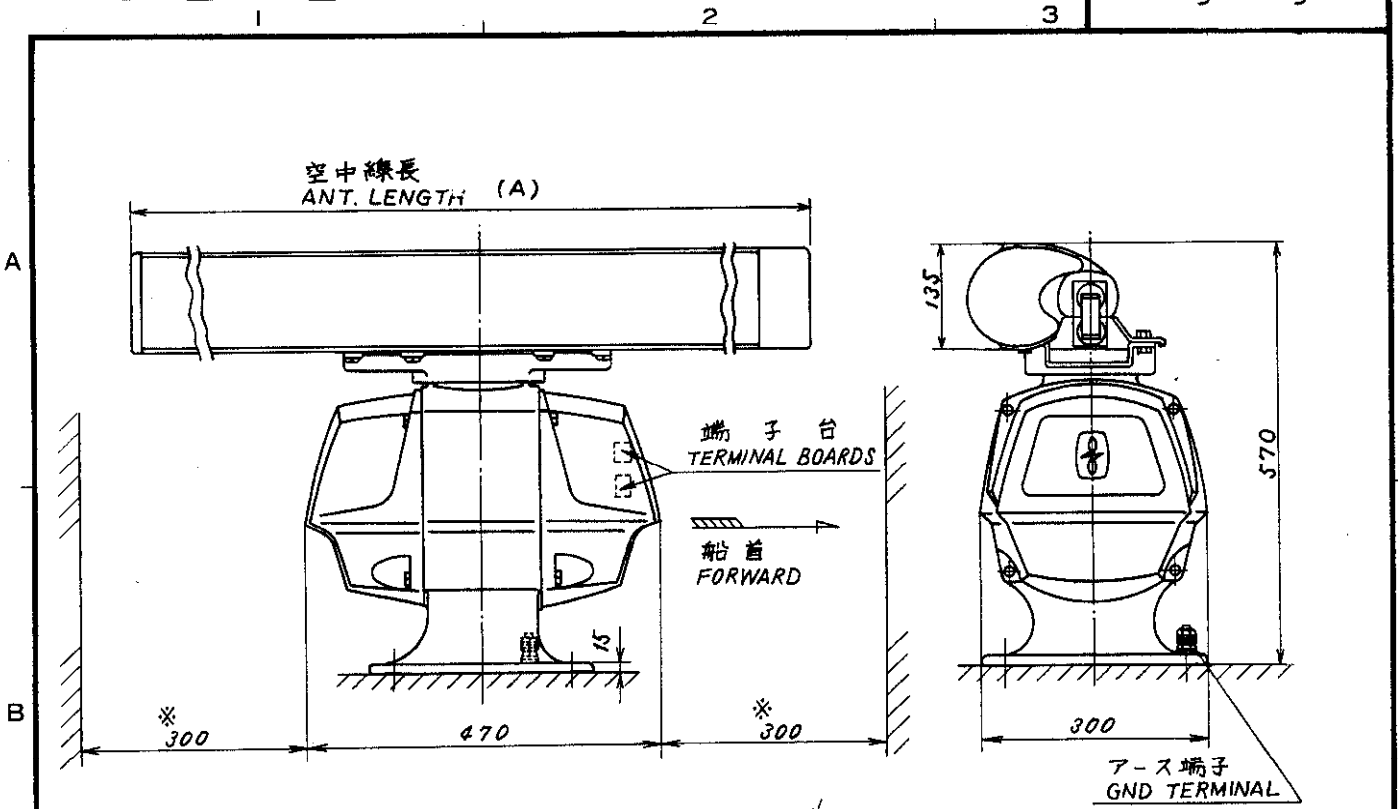

NOTE 1. ※: 推奨サービス空間 RECOMMENDED SERVICING CLEARANCE.

NOTE 2.

種類	200cm型TYPE (XN-3A)	240cm型TYPE (XN-4A)
空中線長 (A) ANT. LENGTH	2070 mm	2570 mm
回転直径 DIA. OF (B) ROTATION	2200 mm	2700 mm
重量 WEIGHT	36.5 kg	38.5 kg

※※ 選択可能な空中線部種類は、レーダー型式により異なる。各仕様を参照のこと。
SELECTABLE ANTENNA TYPE DEPENDS ON RADAR MODEL. SEE INDIVIDUAL SPECIFICATIONS.

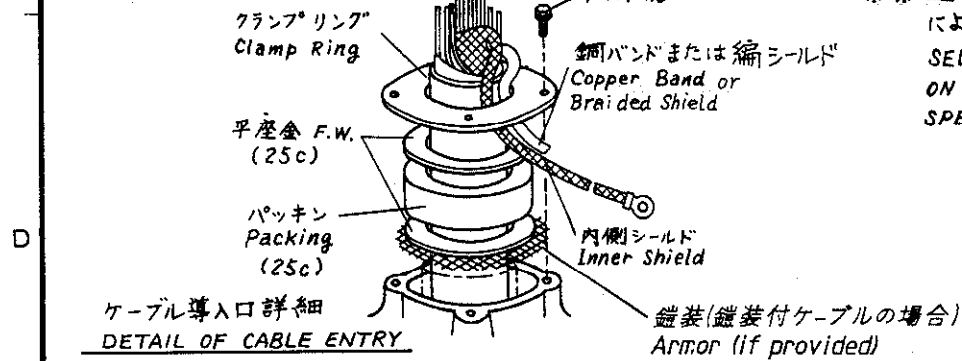

承認 APPROVED	品番 ITEM	品名 NAME	材質 MATERIAL	数量 Q'TY	図番 DWG. NO.	摘要 REMARKS
DEC. 27 '82 K. H.		三角法 THIRD ANGLE PROJECTION				
検図 CHECKED	DEC. 27 '82	尺度 SCALE	名称 TITLE 空中線部外寸図 SCANNER UNIT			
製図 DRAWN	Dec. 27 '82 K. H.	重量 WEIGHT	XN3A/4A-C2P7N2N/ C2P8N2N/ RSB-0063			
		kg	図番 DWG. NO. C3249-011-L			

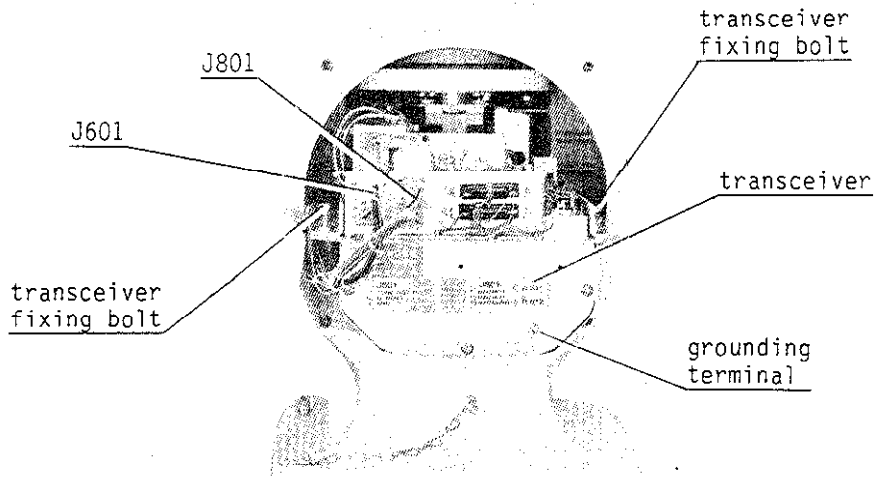

N Photo No 2279

Fig. 5-3 Scanner Unit, Front View, Cover Opened

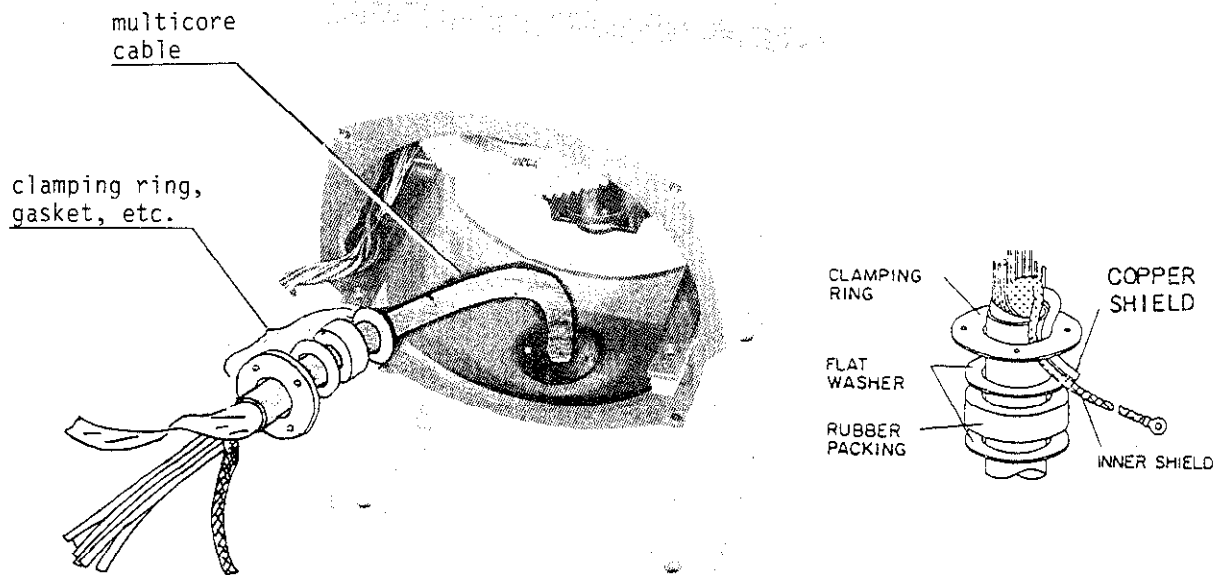

N Photo No. 640

Fig. 5-4 Passing the Multicore Cable Through the Scanner Base

10. Cut the cable to an appropriate length, and fabricate the cable end by referring to the instructions given below.

Fabricating the Multicore Cable

- 11a. Remove 450mm of the vinyl sheath, taking care not to cut the copper shield. (a)
- 11b. Slide the washer, rubber packing, washer, and clamping ring of the cable gland over the cable as shown in (b).
- 11c. Straighten the copper shield and separate the outer layer wires from those in the braided shield (inner wires). (c)
- 11d. Take out the wires and coaxial wire (2C-2V) from the inside layer. (d)
- 11e. Label inner and outer wires to aid identification.
- 11f. Cut each lead wire to a suitable length, taking into consideration the distance to their respective terminals on terminal board RTB801.
- 11g. Remove about 6mm of the vinyl insulation from the end of each wire; then fix a crimp-on lug to each wire using a crimping tool. (e)
- 11h. Spread out the inner shield of the multicore cable and cut it off, leaving about 500mm. Put vinyl tubing or taping over the braided shield and solder a 4mm crimp-on lug at the end of the shield. (f)
- 11i. While holding the wire in one hand, pull on each crimp-on lug to make sure the connection is tight.
- 11j. Peel off about 50mm of the vinyl sheath of the coaxial cable (2C-2V), take out the inner core; and then put crimp-on lug (320882) on the shield ($\phi 4$). Put cloth tape over the shield and core. (f)

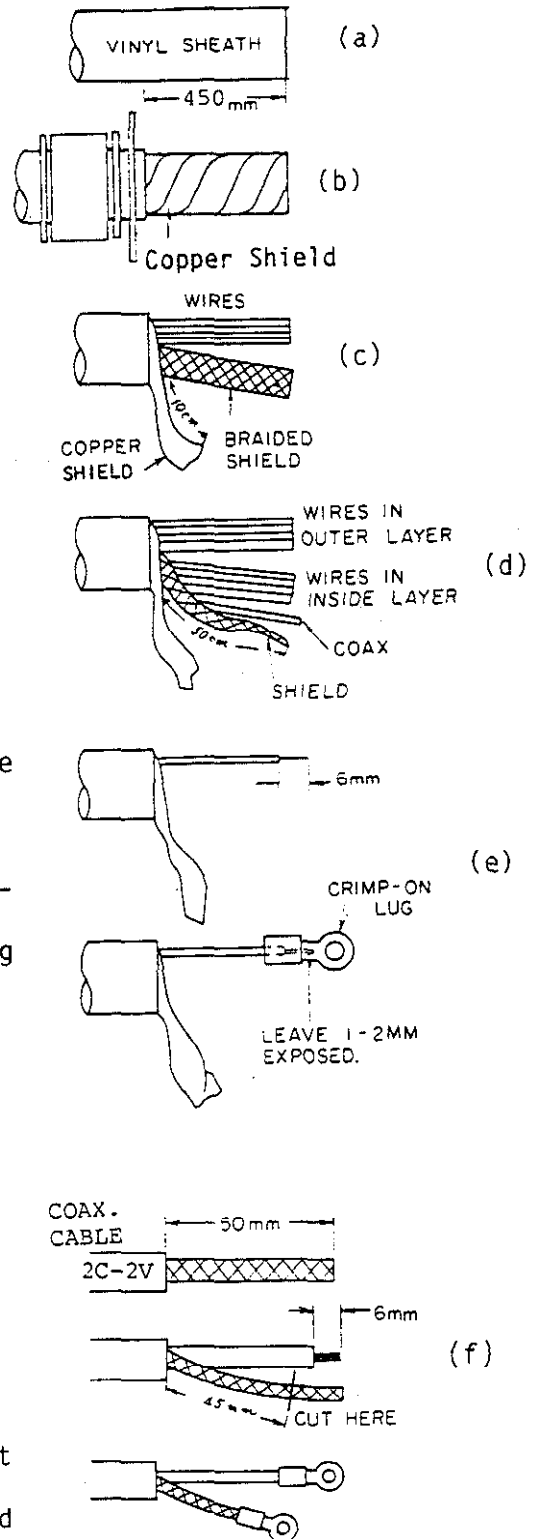

Fig. 5-5 Fabricating the Multicore Cable

Final Preparations Inside the Scanner Housing

12. Tighten the cable gland to the scanner base. Ground the copper shield of the multicore cable with the clamping ring as shown in Fig. 5-6.

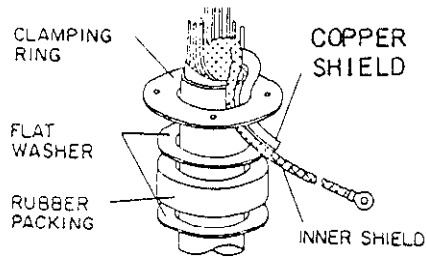
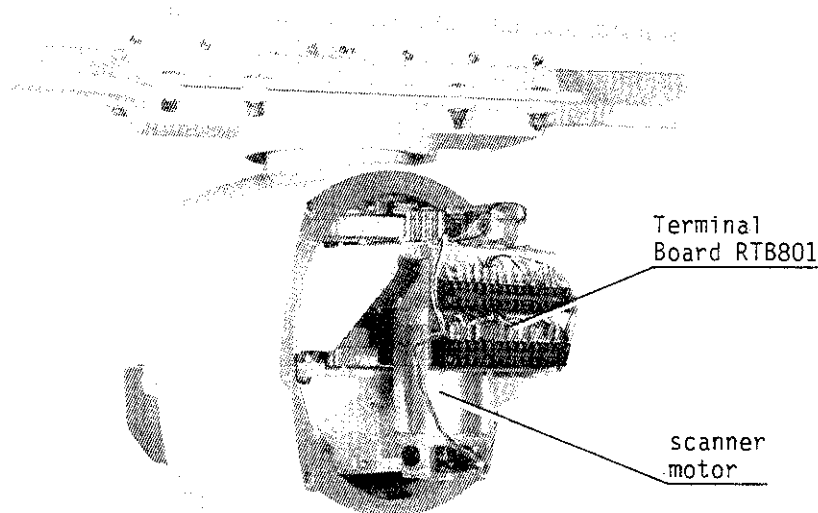

Fig. 5-6 Grounding the Copper Shield

13. Connect the lead wires with crimp-on lugs to terminal board RTB801, referring to Fig. 5-7 and the interconnection diagram on page 5-12. The inner shield of the multicore cable should be connected to the grounding terminal on the RF transceiver module. Replace the scanner housing cover after completing the next section.



N Photo No. 639

Fig. 5-7 Location of Terminal Board RTB801

Assembling the Radiator

Apply silicone sealant to all bolts, nuts and washers to prevent corrosion. Detailed installation instructions are given in the scanner unit assembling drawings on page 5-10 (XN-2/XN-3), or page 5-11 (XN-3A/XN-4A).

14. Apply grease (not silicone sealant) to the O-ring and insert it into the groove of the radiator flange. Fix the feeder waveguide to the radiator flange.
15. Loosely fix the antenna radiator to the radiator bracket.
16. Place the greased O-ring in the groove of the rotary waveguide flange. Fix the feeder waveguide to the rotary waveguide flange.
17. Fix the feeder waveguide to the bottom of the radiator.
18. Tighten the bolts fixing the antenna radiator to the radiator bracket.
19. Replace the transceiver module and secure it with the bolts removed in step 7; reconnect plugs P801 and P601.
20. Ensure all wirings are made correctly.
21. Temporarily close the scanner housing cover. You will need to get inside the housing again to make the heading alignment adjustment.

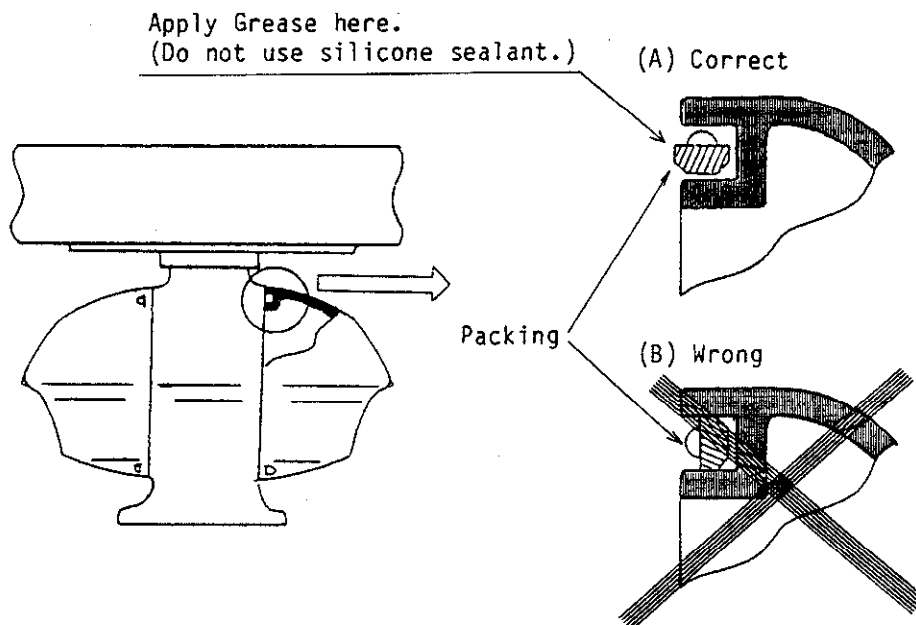

Fig. 5-8 Installing the scanner cover packing

A

B

C

D

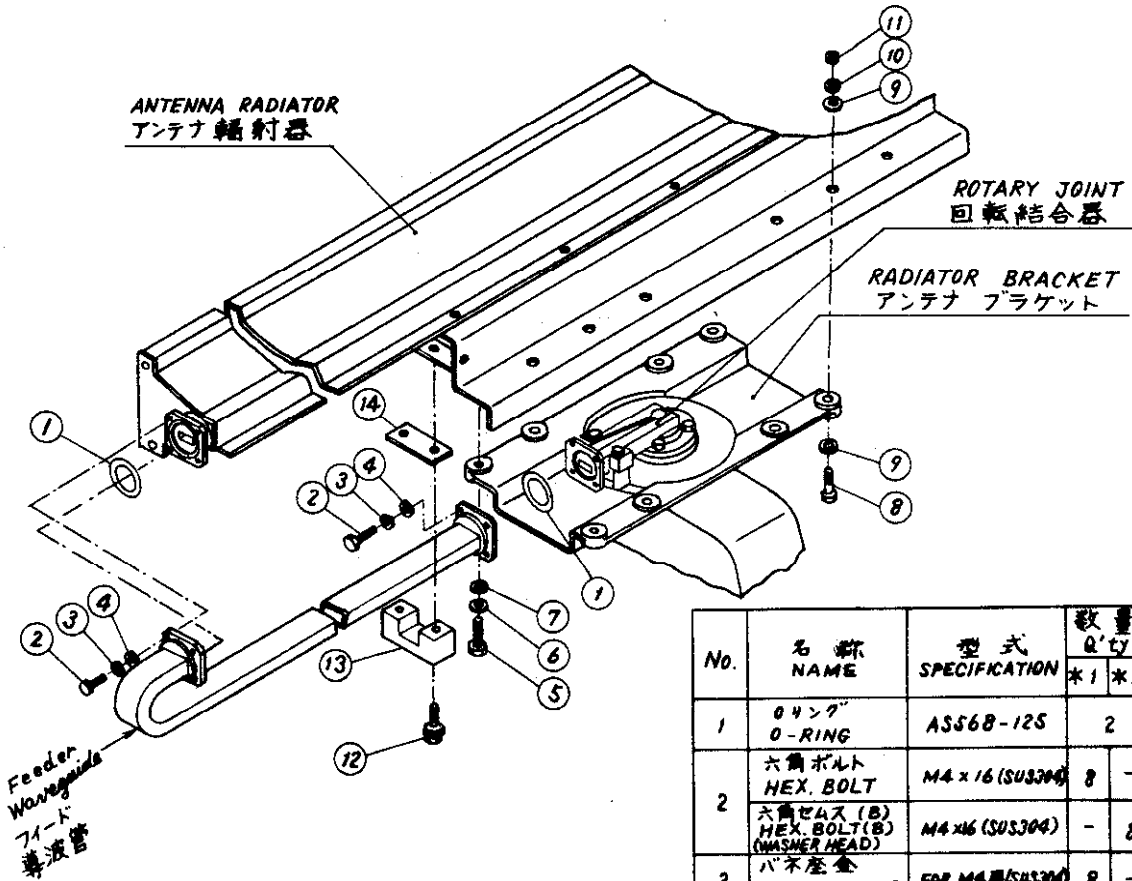

- NOTE 1. 電蝕防止のため、組立時にボルト、ナット、ワッシャ及びフランジ面のOリング溝外側の部分に支給のシリコンシーラント(無酸性)を塗布する。Oリング及びOリング溝には塗布しないこと。
 APPLY SILICONE SEALANT (SUPPLIED, NON-ACID TYPE) ON BOLTS, NUTS, WASHER AND WAVEGUIDE FLANGE OUTSIDE O-RING GROOVE TO AVOID ELECTRICAL CORROSION. (DO NOT APPLY SEALANT TO O-RINGS AND O-RING GROOVES.)
2. Oリングにきずをつけたり、ごみを付着させないように注意の事。
 DO NOT PINCH O-RING AND KEEP IT CLEAN.
3. Oリング及びスキャナーカバーのパッキンにはグリスを使用すること。シリコンシーラントは使用不可。
 FOR PACKINGS OF SCANNER COVERS AND O-RINGS, DO NOT USE SILICONE SEALANT, BUT RATHER USE GREASE.

No.	名称 NAME	型式 SPECIFICATION	数量 Q'ty	
			*1	*2
1	Oリング O-RING	AS56B-125	2	
2	六角ボルト HEX. BOLT	M4×16(SUS304)	8	-
	六角ワッシャ(B) HEX. BOLT(A) (WASHER HEAD)	M4×16(SUS304)	-	8
3	バネ座金 SPRING WASHER	FOR M4用(SUS304)	8	-
4	平座金 FLAT WASHER	FOR M4用(SUS304)	8	-
5	六角ボルト HEX. BOLT	M8×25(SUS304)	4	-
	六角ワッシャ(A) HEX. BOLT(A) (WASHER HEAD)	M6×25	-	6
6	バネ座金 SPRING WASHER	FOR M8用(SUS304)	4	-
7	平座金 FLAT WASHER	FOR M8用(SUS304) RSG-1002-0	4	-
8	六角ボルト HEX. BOLT	M8×30(SUS304)	4	6
9	平座金 FLAT WASHER	FOR M8用(SUS304)	8	12
10	バネ座金 SPRING WASHER	FOR M8用(SUS304)	4	6
11	六角ナット HEX. NUT	M8(SUS304)	4	6
12	六角ワッシャ(B) HEX. BOLT(B) (WASHER HEAD)	M4×25	-	2
13	導波管押え W/G CLAMP	RSB-2006-1	-	1
14	導波管パッキン W/G PACKING	RSB-2008-0	-	1

*1: 900/1230mm アンテナ用 (XN-1/2)
 FOR 900/1230mm RADIATOR (XN-1/2)

*2: 2000mm アンテナ (XN-3) 用
 FOR 2000mm RADIATOR (XN-3)

品番 ITEM	品名 NAME	材質 MATERIAL	数量 Q'TY	図番 DWG. NO.	摘要 REMARKS
承認 APPROVED	MAY. 25. 79	三角法 THIRD ANGLE PROJECTION	名称 TITLE 空中線部組立図 SCANNER UNIT ASSEMBLING		
検 CHECKED	MAY. 25. 79	尺度 SCALE	空中線長 ANT. LENGTH: 900, 1230 & 2000mm (XN-1/2/3)		
製 DRAWN	25. 5. 79	重量 WEIGHT	kg	図番 DWG. NO. C3237-025-H	

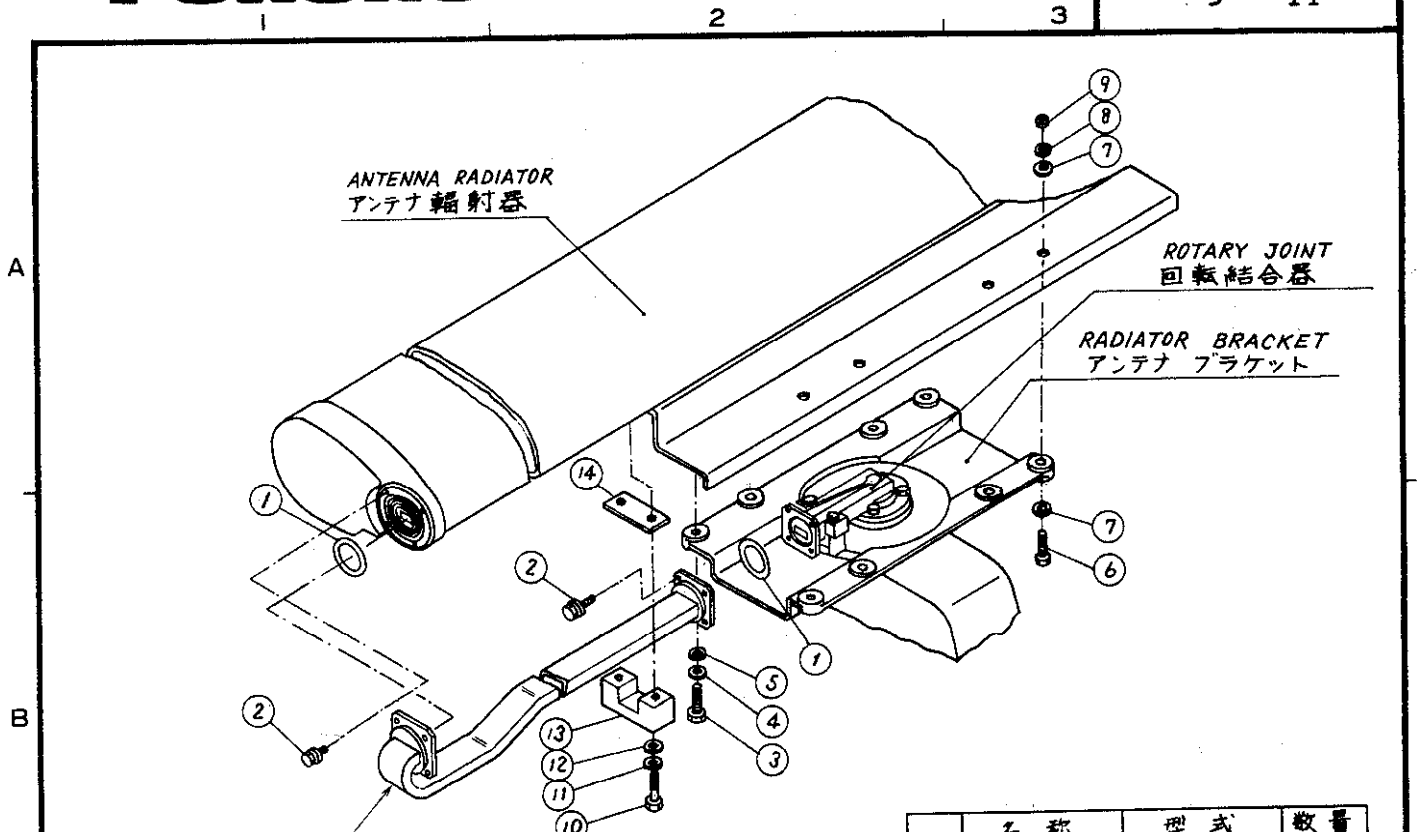

NOTE 1. 電蝕防止のため、組立時にボルト、ナット、ワッシャ及びフランジ面のOリング溝外側の部分に支給のシリコンシール剤(無酸性)を塗布する。Oリング及びOリング溝には塗布しないこと。
 APPLY SILICONE SEALANT (SUPPLIED, NON-ACID TYPE) ON BOLTS, NUTS, WASHER AND WAVEGUIDE FLANGE OUTSIDE O-RING GROOVE TO AVOID ELECTRICAL CORROSION. (DO NOT APPLY SEALANT TO O-RINGS AND O-RING GROOVES.)

2. Oリングにきずをつけたり、ごみを付着させないように注意の事。
 DO NOT PINCH O-RING AND KEEP IT CLEAN.

3. Oリング及びスキャナカバーのパッキングにはグリスを使用すること。シリコンシール剤は使用不可。
 FOR PACKINGS OF SCANNER COVERS AND O-RINGS, DONOT USE SILICONE SEALANT, BUT RATHER USE GREASE.

No.	名称 NAME	型式 SPECIFICATION	数量 Q'TY
1	Oリング O-RING	ASS68-125	2
2	六角セムス(B) HEX. BOLT(B) (WASHER HEAD)	M4x16 (SUS304)	8
3	六角ボルト HEX. BOLT	M8x35(SUS304)	4
4	バネ座金 SPRING WASHER	FOR M8用(SUS304)	4
5	平座金 FLAT WASHER	FOR M8用(SUS304)	4
6	六角ボルト HEX. BOLT	M8x25 (SUS304)	4
7	平座金 FLAT WASHER	FOR M8用(SUS304)	8
8	バネ座金 SPRING WASHER	FOR M8用(SUS304)	4
9	六角ナット HEX. NUT	M8(SUS304)	4
10	六角ボルト HEX. BOLT	M4x30(SUS304)	2
11	バネ座金 SPRING WASHER	FOR M4用(SUS304)	2
12	平座金 FLAT WASHER	FOR M4用(SUS304)	2
13	導波管押え W/G CLAMP	RSB-2006-1	1
14	導波管間座 W/G PACKING	03-003-4003-0	1

承認 APPROVED	品番 ITEM	品名 NAME	材質 MATERIAL	数量 Q'TY	図番 DWG. NO.	摘要 REMARKS
MAY. 25. '79		三角法 THIRD ANGLE PROJECTION				
検査 CHECKED	MAY. 25. '79	尺度 SCALE				名称 TITLE 空中線部組立図 SCANNER UNIT ASSEMBLING (XN3A/XN4A)
製図 DRAWN	25. 5. 79	重量 WEIGHT	kg		図番 DWG. NO.	C3249-017-F

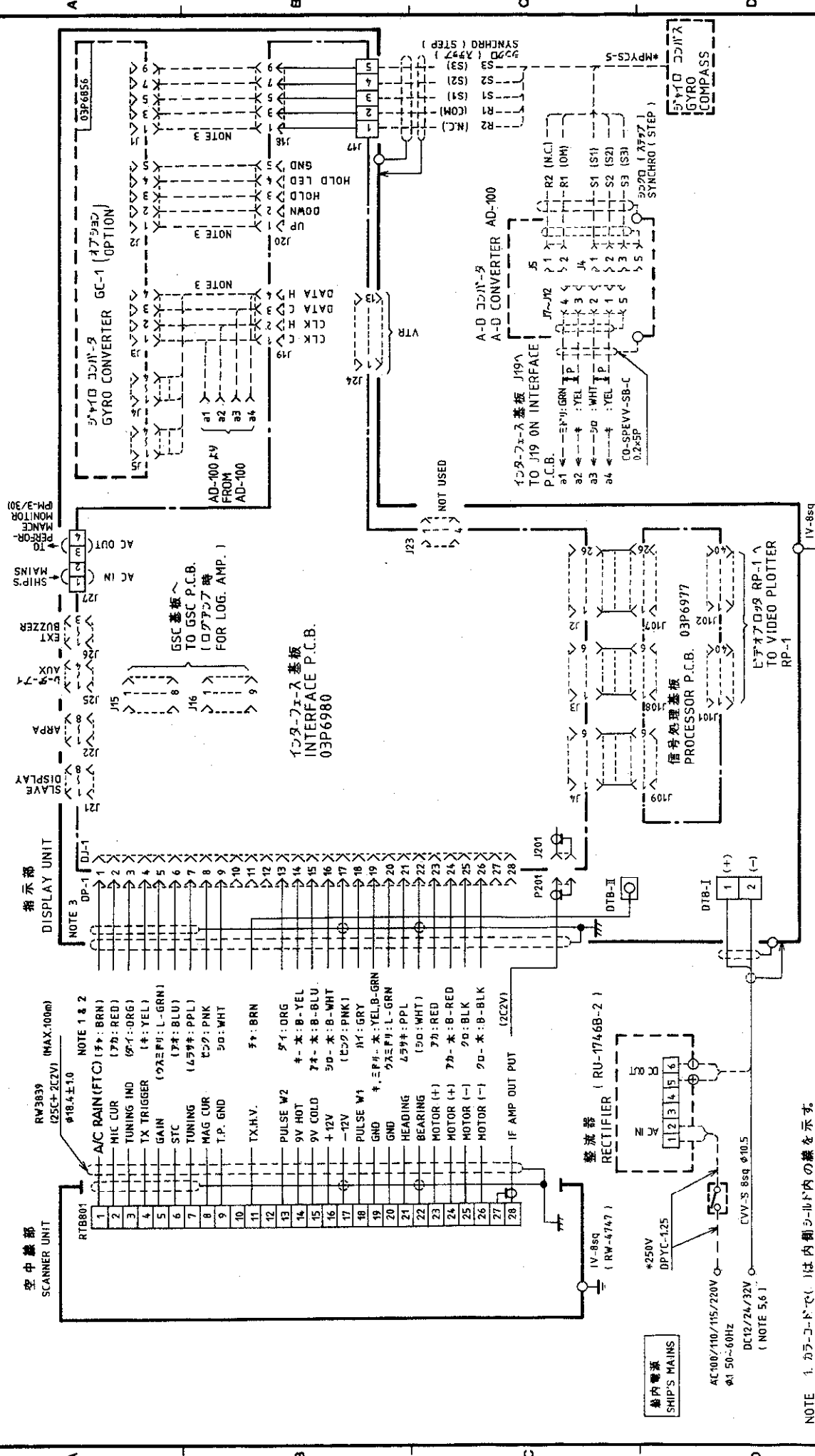

承認 APPROVED T. NAKANO (Date: 17. 87)

検閲 CHECKED I. Amano (Date: 16. 87)

製図 DRAWN Y. Tomiyama (Date: 16. 87)

名 稱 FR-1500D (A) SERIES

題 目 相互結線図

INTERCONNECTION DIAGRAM

図 番 C3307-023-E

DWG. NO.

- NOTE
1. カラーコードで()は内側、()は外側の線を示す。 WIRE COLOR CODE () : INSIDE B-BIG WIRE, L-LIGHT COLOR.
 2. カラーコードは両ユニット側で完全にアースすること。 SHIELD SHOULD BE EFFECTIVELY GROUNDED AT BOTH UNIT ENDS.
 3. コネクタが取り付け済みの場合、コネクタプラグを工場出荷状態で取り外さないこと。 SHIPYARD SUPPLY.
 4. * : 造船所支給。 SHIPYARD SUPPLY.
 5. 240cm空中線取付の場合にはDC24V電源のみ。 ONLY DC24V MAINS FOR 240cm TYPE ANTENNA RADIATOR.
 6. FR-1525D(A)の場合DC12V電源は使用しない。 DO NOT USE 12VDC MAINS FOR FR-1525D(A).

DISPLAY UNIT INSTALLATION

Siting Considerations

Locate the display unit in a place where it can be viewed and operated conveniently but where there is no danger of salt or fresh water spray or immersion.

The magnetic compass may be affected if the display unit is placed too close to it, because of the magnetic fields generated in the radar. The compass safe distance; 1.9 meters for standard compass, 1.1 meters for steering compass, must not be disregarded.

The orientation of the display unit should be so that the radar screen is viewed while the operator is facing the bow. This makes determination of position much easier.

The mount can be installed either on a bulkhead or on a tabletop. The mounting dimensions for this unit are shown on page 5-15. You can use the mounting cradle itself as a template for marking the mounting bolt holes. Since the unit weights 21 kg reinforce the mounting place, if necessary.

Make sure you allow enough clearance to get to the connectors behind the unit. Leave at least a foot or so of "service loop" of cables behind the unit so that it can be pulled forward for servicing or easy removal of the connectors. The recommended clearances for servicing ease are given on page 5-15.

Mounting

Tabletop

1. Remove the two bolts (M8x35) fixing the display unit to the mounting cradle.
2. Drill four mounting holes (12mm dia.) through the tabletop.
3. Secure the mounting cradle to the tabletop by using M10 bolts, nuts and washers. 9mm radius coach screws may be substituted for the M10 bolts.
4. Place the display unit on the mounting cradle and secure them at the front of the display unit with the two bolts removed in step 1.

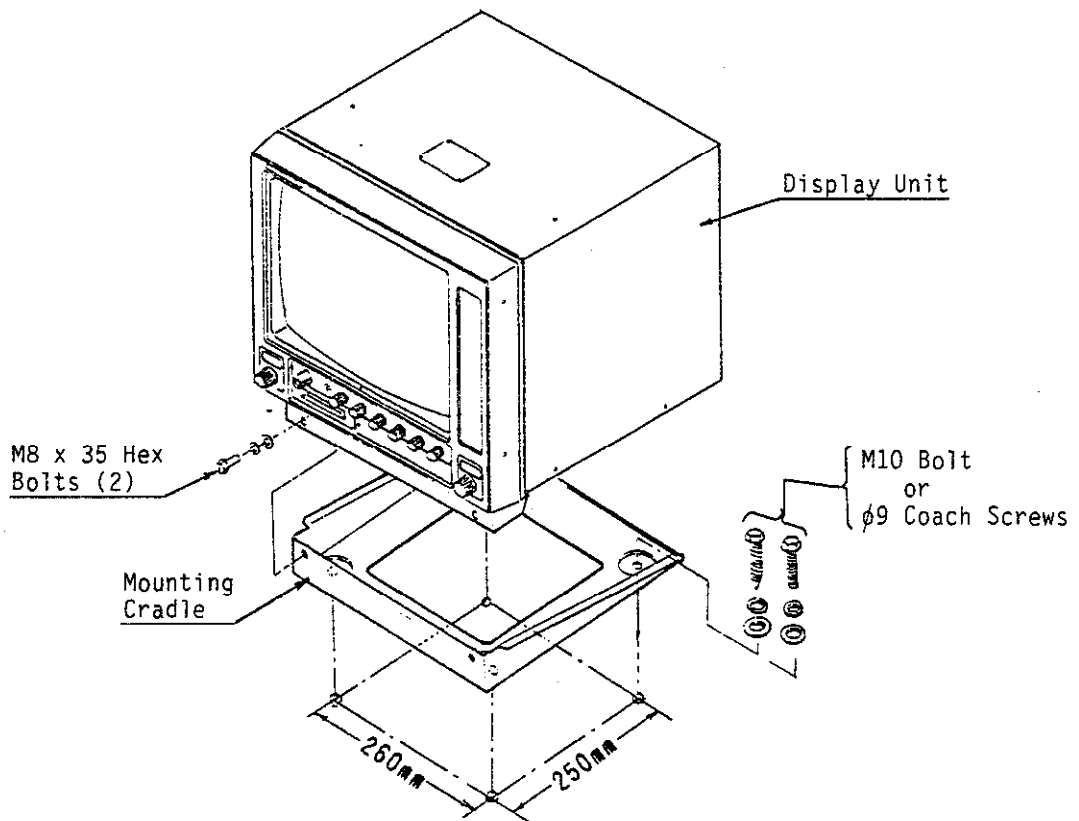
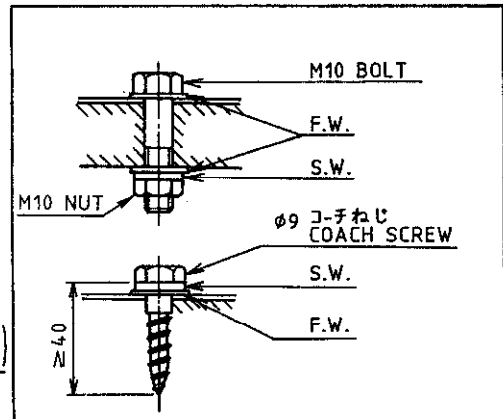
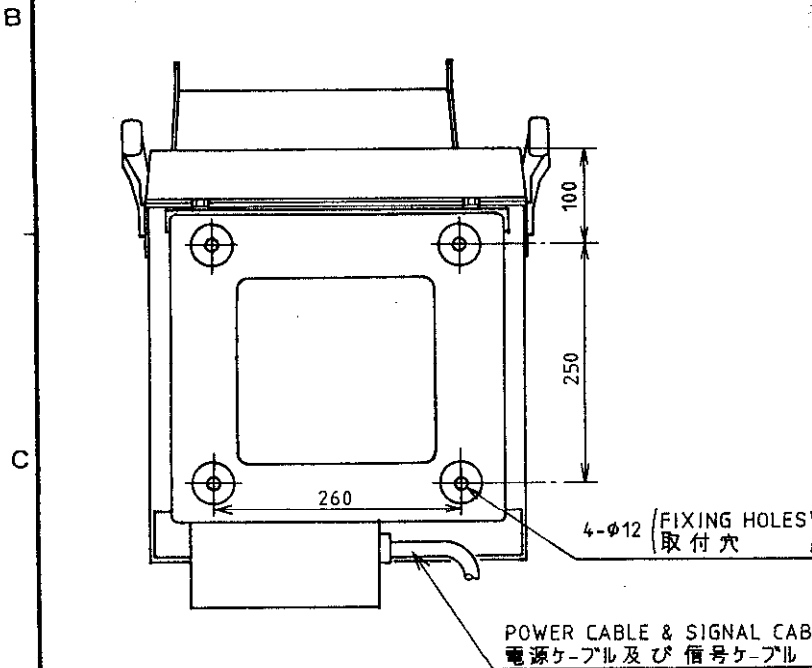
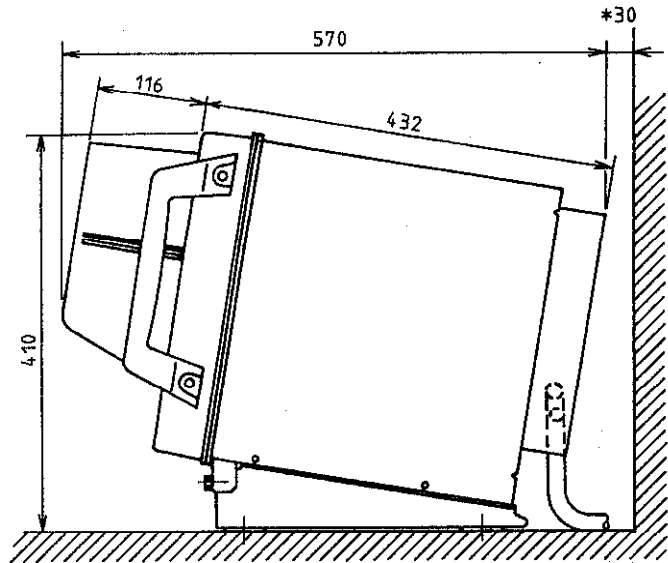
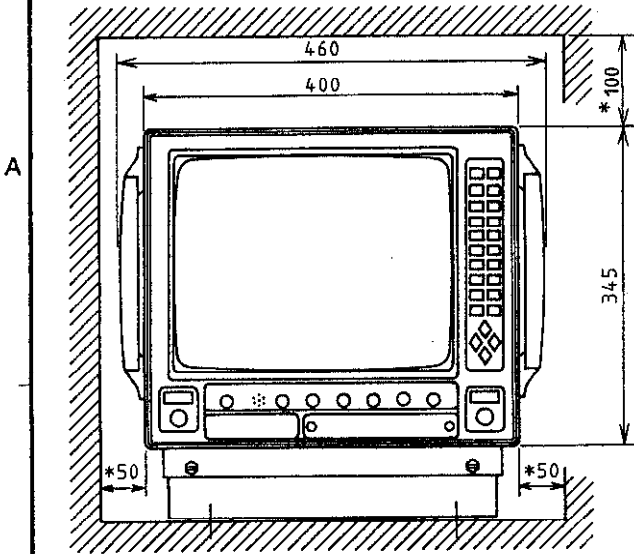

Fig. 5-9 Tabletop Mounting



- NOTE 1 * : 推奨サービス空間。
RECOMMENDED SERVICING CLEARANCE.
- NOTE 2 : 装備ケーブルはサービス時、指示部を前方に十分引き出せるよう余裕をもたせること。
SUFFICIENT EXTRA CABLINGS SHOULD BE ALLOWED AT THE BACK OF THE UNIT SO THAT THE UNIT CAN BE DRAWN OUT WITH THE CABLES CONNECTED FOR MAINTENANCE.

FR-1500DS SERIES FR-1500D(A) SERIES	品番 ITEM	品名 NAME	材質 MATERIAL	数量 Q'TY	図番 DWG.NO.	摘要 REMARKS
承認 APPROVED	MAY 28, '87 T. NAKANO	三角法 THIRD ANGLE PROJECTION	名称 TITLE			レダ-指示部外寸図 RADAR DISPLAY UNIT
検図 CHECKED	MAY 28 '87 I. Amano	尺度 SCALE	1/8			
製図 DRAWN	May. 28. '87 Y. Tomiyama	重量 WEIGHT	21 kg	図番 DWG.NO.	C3307-020-E	

Bulkhead

1. Take the top cover off by loosening the six cosmetic screws (M4x10).
2. Loosen the two M8x35 hex bolts at the front of the display unit.
3. Loosen the eight M6x16 hex bolts and four M3 flat head screws; and then separate the mounting cradle from the bottom plate.
4. Secure the mounting cradle and bottom plate to the top of the display as shown in the figure below.

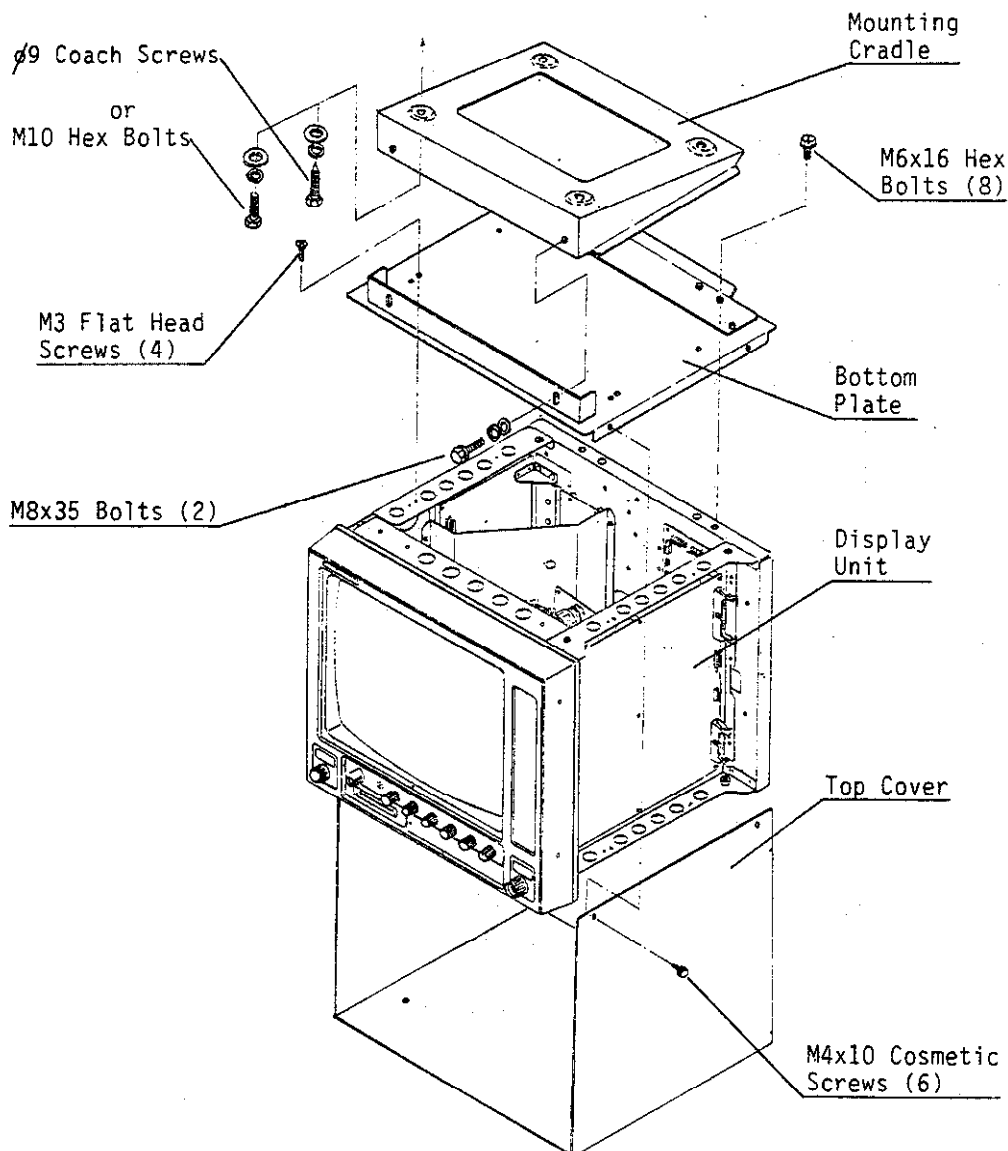

Fig. 5-10 Bulkhead Mounting

Connections

Two cables run to the display unit, the multicore cable from the scanner unit and the power cable from the ship's mains or rectifier. The multicore cable is terminated with factory-wired connectors at the display side. Fabricate the power cable as follows.

Fabricating the Power Cable

5. Remove 200mm of the vinyl sheath, taking care not to nick the braided shield.
6. Unwind the cloth tape and cut it off.
7. Take off about 40mm of the inner core of the braided shield; cut off the jute.
8. Remove about 10mm of the insulators from the cores and fix $\phi 4$ soldering lugs to the cores.
9. Wrap the braided shield with vinyl tape, leaving space for a clamp to make good electrical cable.

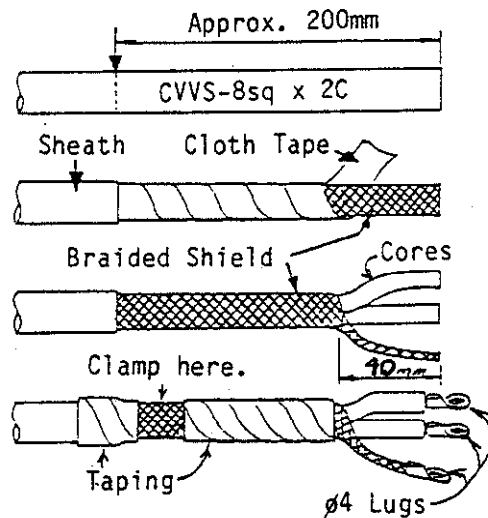

Fig. 5-11 Fabricating the Power Cable

Connecting the Multicore Cable

10. Expose the copper shield of the multicore cable by removing the vinyl tape at the point shown below.

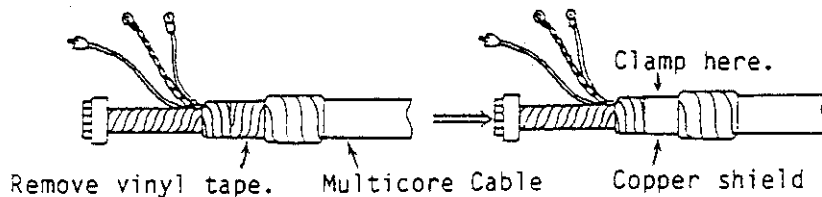
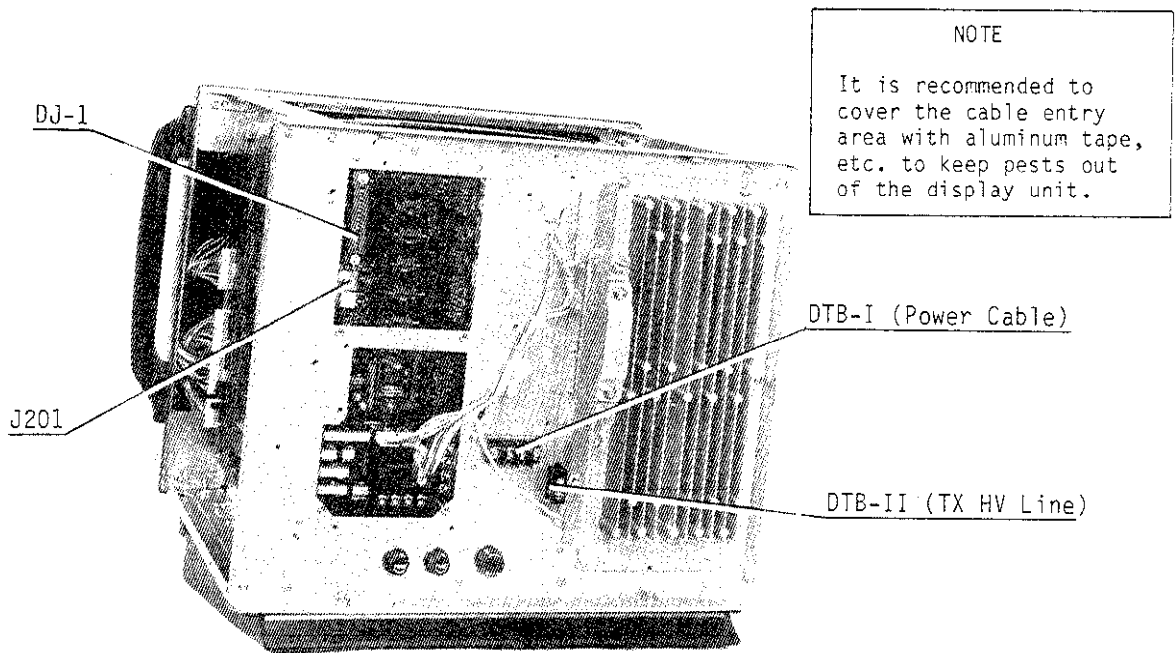

Fig. 5-12 Multicore Cable (Display Unit side)

11. Take off the rear cover by loosening eight fixing screws.
12. Separate the clamp plate from the cable clamp by loosening two hex bolts. Then secure the multicore cable and power cable so that the cable shield is completely grounded thru the clamp.

13. Cables of optional equipment are also secured by the cable clamp.
14. Dress the end of the multicore cable through the cutout in the rear panel; and then connect the coaxial cable plug P201, multicore cable connector DP-1, TX HV line and inner shield of the multicore cable.
15. Ground the inner shield of the multicore cable to the display chassis through the screw beside the terminal board DTB-II.
16. Connect the power cable to terminals DTB-I on the line filter; positive core to #1 and negative core to #2. Connect the shield of the power cable to the earth terminal above the filter.



N Photo No.2246

Fig. 5-13 Display Unit, Rear View

Adjustment on the Power Supply Board

There are some jumper wires which are necessary to be changed with respect to the mains input 24-32VDC. The board is located on the left side of the display unit and the jumpers are accessible when the display cover is removed.

<u>Jumper</u>	<u>24 or 32V</u>
JA-1	No jumper
JA-2	Common-H
JA-3	Common-H
JA-4	Common-H
JA-5	Common-H

The 8ft radiator (XN-4A) can be used when the ship's mains is 24VDC. The jumper terminal JA-6 is bridged as shown on the next page.

Radiator	2.4m (8ft)	1.2m (4ft) and 2m (6.5ft)
Jumper JA-6	SC-SM	SC-INV

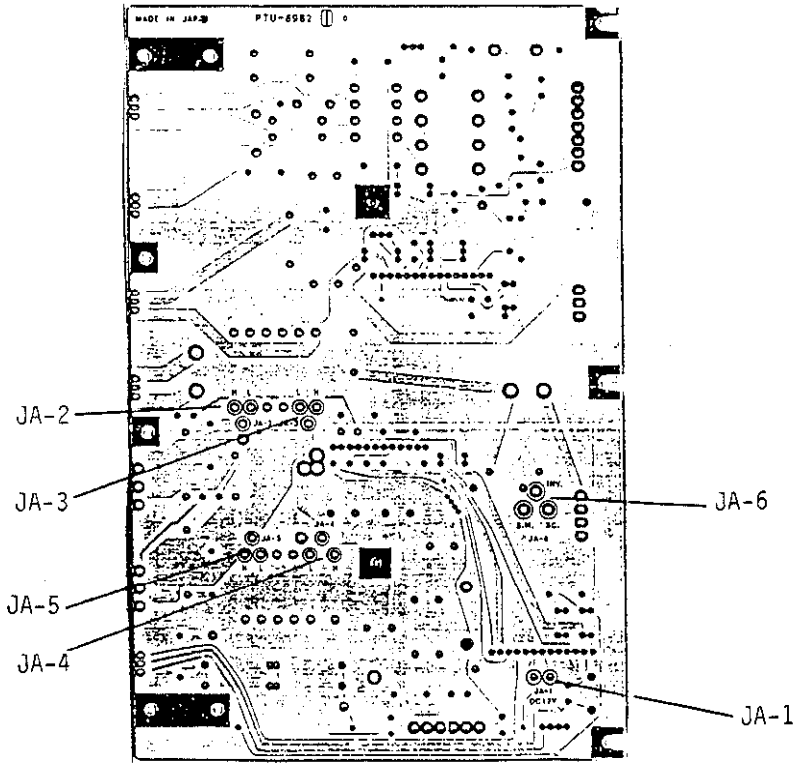

Figure 5-14 Power Supply Board

RECTIFIER UNIT INSTALLATION AND CONNECTION

For the set driven by 100/110/115/220VAC ship's mains a rectifier unit (RU-1746B-2) is required. The unit can be mounted in any dry, well-ventilated place. The mounting dimensions are shown in the outline drawing on the next page. The compass safe distance, 1.8 meters, standard compass; and 1.0 meters, steering compass, should be observed.

For connection to this unit, refer to both the diagram on the next page and the interconnection diagram on page 5-12.

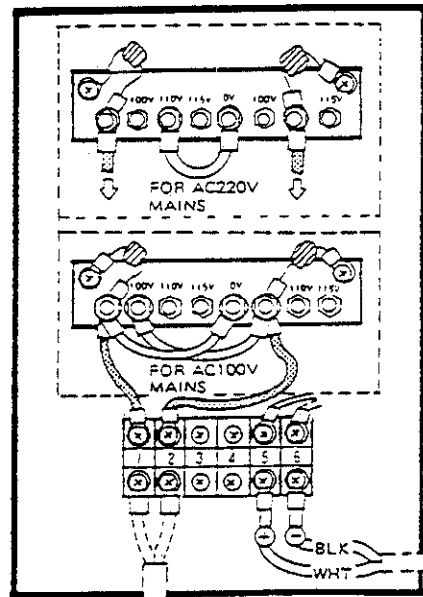
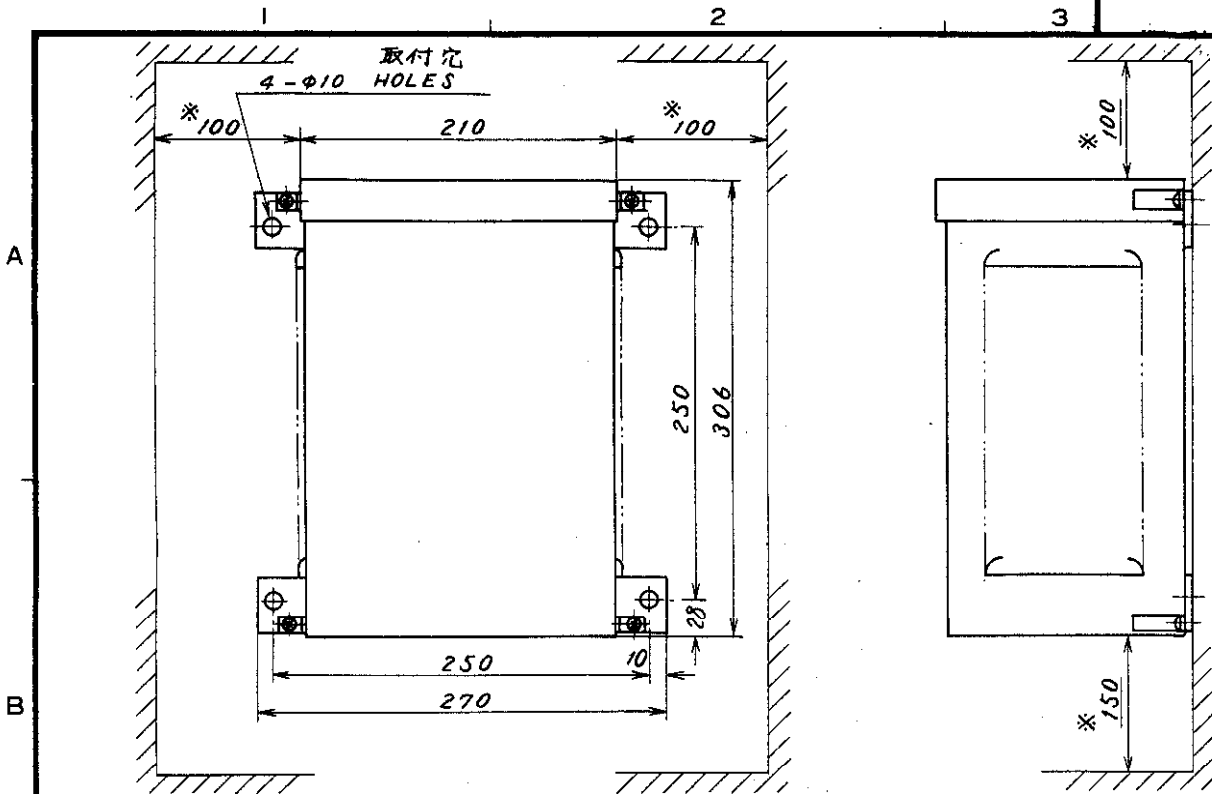
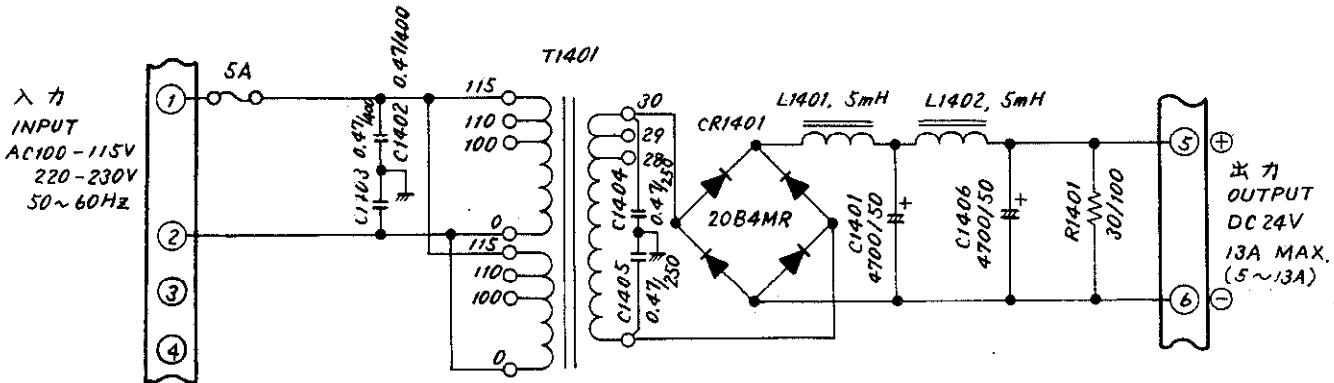
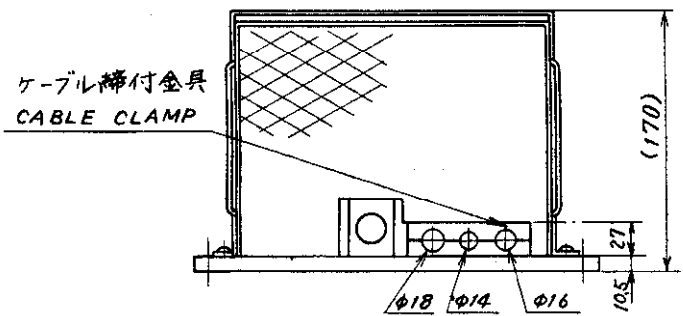

Figure 5-15 Connections to the Rectifier Unit



NOTE 1. *: 推奨サービス空間
RECOMMENDED SERVICING CLEARANCE.



注 AC220V 入力に対しては T1401 の一次巻線を直列に接続する。

NOTE FOR 220VAC INPUT, CONNECT T1401 PRIMARY WINDINGS IN SERIES.

承認 APPROVED	品番 ITEM	品名 NAME	材質 MATERIAL	数量 Q'TY	図番 DWG.NO.	摘要 REMARKS
OCT. 17. '78		三角法 THIRD ANGLE PROJECTION				名称 TITLE 整 流 器 RU-1746B-2 RECTIFIER UNIT
CHECKED		尺 度 SCALE				
DRAWN		重 量 WEIGHT		17 kg	図 番 DWG.NO.	C 3 0 0 2 - 0 0 2 - L

ADJUSTMENT AT INSTALLATION

Preoperation Checks

After completion of all wiring and interconnections, check that there is no wrong nor loose connection on the terminal boards. Check that the connectors and circuit boards are firmly connected to respective jacks and plugs. Then, apply the power and check radar functions item by item according to the following procedure.

1. Set the controls as follows.

POWER switch ----- OFF
 SCANNER switch ----- OFF
 CRT BRILLIANCE control -- fully counterclockwise
 A/C RAIN FTC control ---- " , FTC disengaged
 A/C SEA control ----- "
 GAIN control ----- "

Turn the power on and confirm that the input voltage at the terminals #1 and #2(-) of DTB-I on the filter are as below. (If the power is supplied through a rectifier, change of tap connection in the transformer may be required. See page 5-20.)

Specified Voltage	Allowance
12VDC	10.2 to 15.0VDC
24V-32VDC	20.4 to 40VDC

2. In about 3 minutes after switching on the radar, the indication ST-BY is displayed on the screen. Turn the SCANNER switch to ON and check that the antenna rotates at a speed between 20 and 25 rpm.

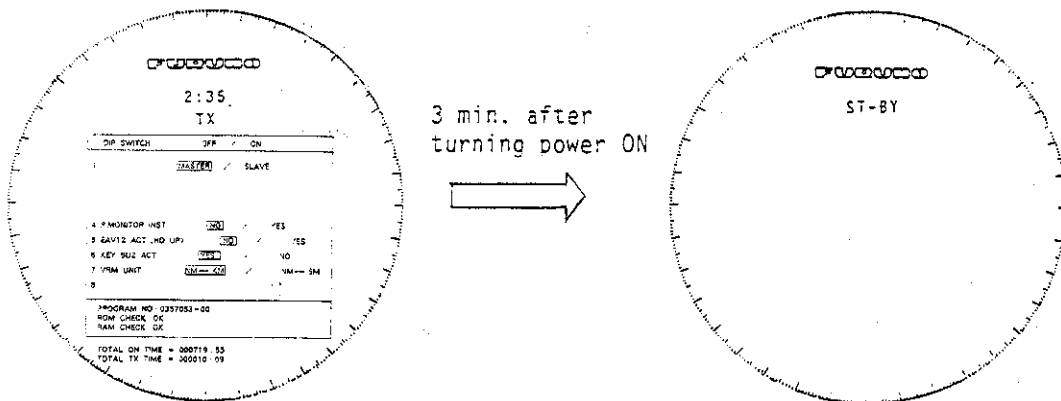

Fig. 5-16

3. Press the [STBY/TX] touchpad to begin transmitting.
4. Gradually turn the GAIN control clockwise, and confirm that noise and/or echoes appear on the CRT.
5. Adjust the TUNE control to obtain best tuning.
6. Check the function of other controls, switches and touchpads by operating them one by one.

Adjustments

The location of the controls in the preset compartment is shown below.

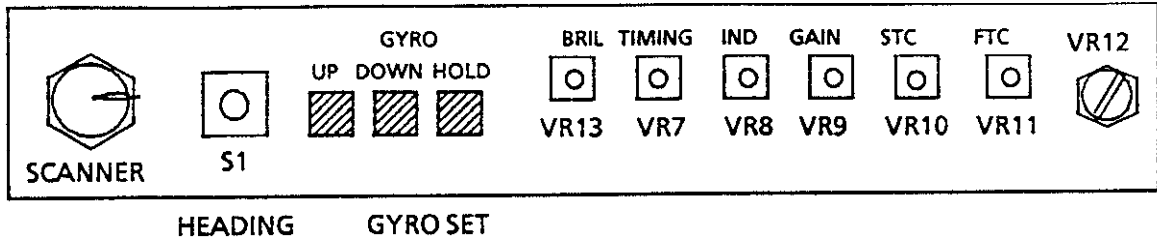

Fig. 5-17 Location of Controls in the Preset Compartment

Transmission Timing

Transmission timing differs with respect to the length of the multicore cable between the display and the scanner units. It has been adjusted for a nominal cable length of 10m at the factory, so even if the standard cable length is used the adjustment must be performed. The following problems may occur if the adjustment is not made.

*Straight wharf or breakwater appears bent inward or outward at the center of the screen on the 0.25 nm range. (See Fig. 5-18.)

*Range error is found on short range.

*Dark area appears at the center of the screen.

The adjustment is made with VR7 while observing the radar screen.

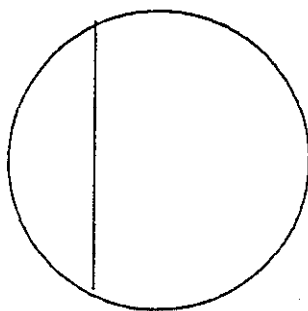

a. PROPER SETTING
Straight target
appears as a
straight line
on screen.

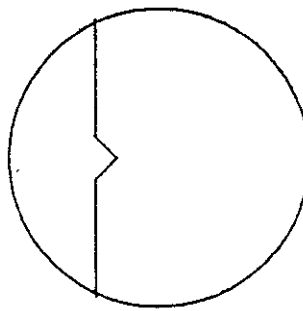

b. TURN VR7 CCW
TO CORRECT.
Straight target
is pulled inward.

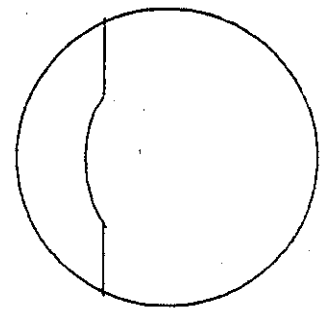

c. TURN VR7 CW
TO CORRECT.
Straight target
is pushed outward.

Fig. 5-18 Adjusting VR7

Heading Alignment

The heading mark should appear on the screen at the instant the radar beam passes the ship's bow. This adjustment should be made by observing the picture on the screen rather than being done mechanically because the direction of the emitted radar beam is not perpendicular to the radiator aperture but deviates by a certain amount--the squint angle. At the operating frequency of this radar system, the squint angle is about 2.5 degrees advanced in the turning direction of radiator.

To do this job efficiently, two persons are usually needed, one at the display and the other at the scanner. Use of hand-held communication transceivers makes the adjustment easier.

1. Set the range between 1.5 and 3 nm; select the Head-up mode; and operate the radar to obtain a normal picture on the screen.
2. Select a suitable target echo (small island, end of quay, etc.) located on or around the heading mark and near the edge of the screen.
3. Press the ON portion of the [EBL] touchpad to present an EBL on the screen.
4. Operate the rotary knob control until the EBL bisects the target.
5. On a navigational chart find the relative bearing of the target from the ship's heading, noting the exact direction of the ship's heading when doing so. Relative bearing can also be found by visually measuring the direction of the target from the ship's bow with a dumb card.

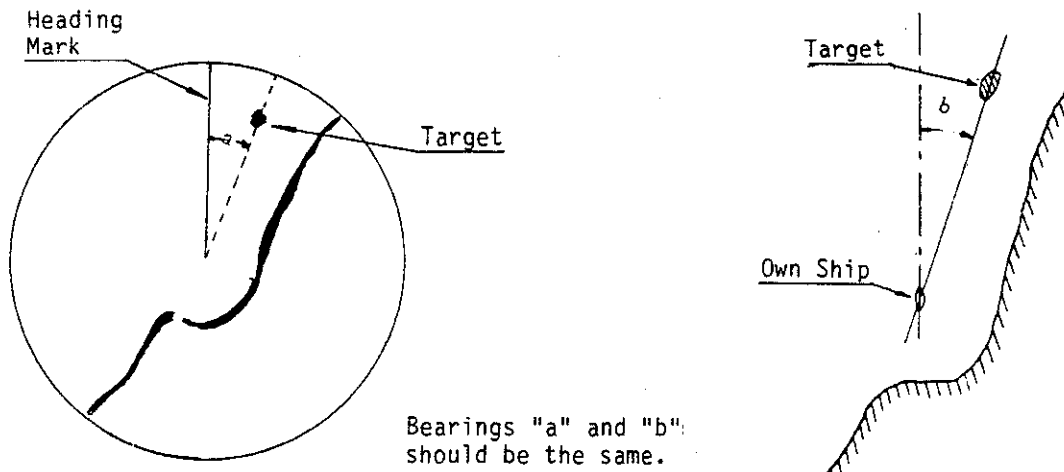

Fig. 5-19 Heading Alignment

6. The bearing of the target from the heading mark should be the same as that found on the navigational chart or the visual measurement. If there is a difference between them adjust the Heading Alignment S1 (working range: $\pm 5.6^\circ$ in steps of 0.7° . Clockwise turning shifts the picture CW.)

Tuning & Tuning Indicator Sensitivity

Optimum tuning should be obtained with the maximum number of tuning markers displayed. If not, take the following procedure.

1. Set controls and switches as follows.

RANGE: 48 nm, GAIN: properly adjusted, A/C SEA & A/C RAIN: fully CCW
ECHO STRETCH & INTERFERENCE REJECTOR: OFF, TUNE: center position

2. Turn on the transmitter and wait until magnetron oscillation becomes stable, 10 minutes approx.
3. Adjust VR12 to display the maximum number of tuning markers.
4. Turn VR8 Tuning Indicator in the preset compartment fully CW and turn back CCW gradually until four tuning markers of the tuning bar light up with the fifth marker blinking.

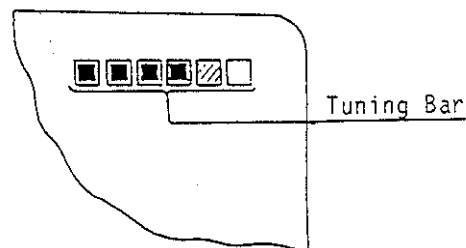

Fig. 5-20 Tuning Bar

Main Bang Suppression

After the transmission timing adjustment is made, perform the following procedure to minimize the main bang effect.

1. Transmit the radar on 0.25 nm and adjust the GAIN and A/C SEA controls for the best picture definition.
2. Find VR1 (MBS Pot.) on the STC Board in the scanner unit.
3. Turn VR1 CW until a black circle of 20-30m (0.014 nm) in radius is obtained at the screen center (sweep origin).

NOTE: Too high a setting of MBS will cause the target echo in close ranges to disappear.

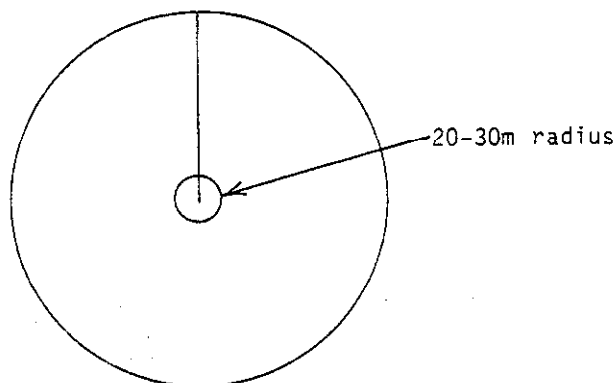

Fig. 5-21 Suppressing the Main Bang

Magnetron Heater Voltage

If the length of the multicore cable is different from the standard one (15m), the Magnetron Heater Voltage should be adjusted as follows. See Fig. 5-22 for the location of test points.

1. Operate the radar in Stand-by, 0.25 nm range, scanner rotation suspended and minimum CRT brilliance.
2. Connect a multimeter, set to the 10VDC range, between J801 #12(positive) and #11(negative).
3. Adjust the position of the sliding contact of R812 for a multimeter reading of 7.0 to 7.6V.

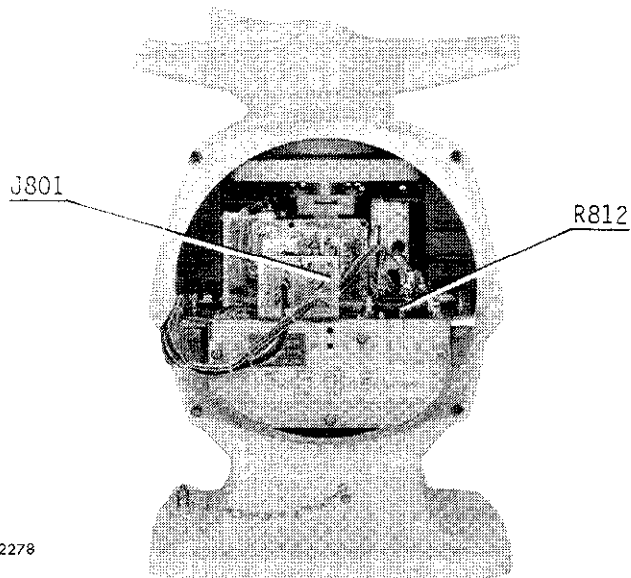

Fig. 5-22 Location of Test Points Used to Adjust Magnetron Heater Voltage

APPENDIX A SETTING TOTAL ON TIME & TOTAL TX TIME

The total on time (no. of hours the power has been applied) and the total TX time (radar transmission time) are displayed for 3 minutes when the power is turned on.

These times are useful to keep track of maintenance intervals, magnetron life, etc. Accordingly, when the radar is first installed or major parts (e.g., magnetron) are replaced, the times should be changed.

Procedure

1. Turn the power on and set the radar to ST-BY.
2. While pressing and holding down the [HM OFF] touchpad, alternately press the [+] and [-] touchpads five times each.
3. Release hold of the [HM OFF] touchpad. The total on time and total TX time are displayed and a cursor circumscribes the first numeral on the "TOTAL ON TIME" line.

↙ Cursor

```
TOTAL ON TIME : 0 0 0 2 3 1 : 0 9
TOTAL TX TIME : 0 0 0 1 9 8 : 0 9
```

4. Press the [+] / [-] touchpads to set the cursor on the desired position; press the [+] touchpad to advance the cursor, or press the [-] touchpad to move the cursor reversely.

The cursor moves in the direction of the arrow each time the [+] touchpad is pressed.

```
ON TIME : [ 0 0 0 2 3 1 : 0 9 ]
TX TIME : [ 0 0 0 1 9 8 : 0 9 ]
```

Press the [-] touchpad to reverse cursor movement.

5. After placing the cursor on the desired numeral, press and hold the [HM OFF] touchpad and then press the [+] or [-] touchpad to count the numeral (0-9) upward or downward, respectively.
6. Repeat steps 4 and 5 to change other numerals.
7. Press the [STBY/TX] touchpad to return to the normal operating mode.

APPENDIX B DIP SWITCH

The specifications of this radar can be changed by switching the settings of a DIP switch on the PROCESSOR board. The specifications of each switch are given in the table below.

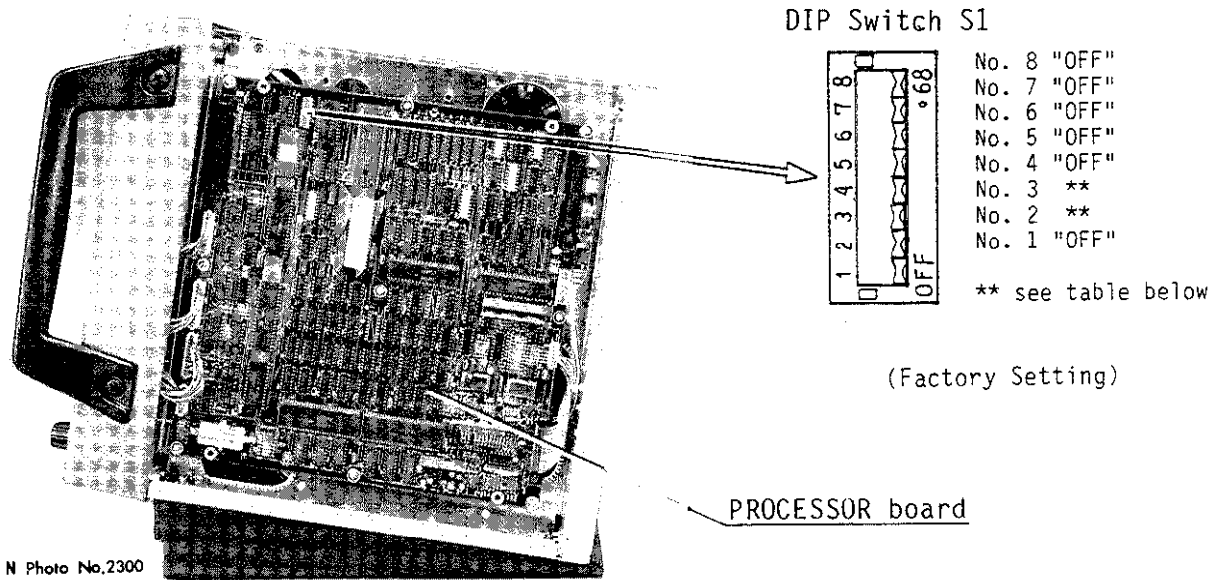

Fig. B-1 Display Unit,
Cover Removed

No.	Specification	OFF	ON
1	Radar Selection	main radar	sub radar
2	Change the setting as shown in right	FR-1505D(A) NO.2 OFF	No.3 OFF
3		FR-1510D(A) No.2 ON	No.3 OFF
		FR-1525D(A) No.2 OFF	No.3 ON
4	Performance Monitor Connection	NO	YES
5	Use of Echo Averaging Levels 1 & 2 in the Head-up Mode	NO	YES
6	Key Operation Confirmation (beep tone)	YES	NO
7	Variable Range Marker Unit	NM/KM	NM/SM
8	Either transmission stops or not when antenna rotation is suspended (*)	YES (ST-BY)	NO (TX)

(*) Not used for program version no. 0.

The settings of the DIP switch are displayed for 3 minutes after the power is turned on. Active settings are circumscribed.

DIP SWITCH		OFF	/	ON
1		<input checked="" type="checkbox"/> MASTER	/	SLAVE
4	P.MONITOR INST	<input checked="" type="checkbox"/> NO	/	YES
5	EAV12 ACT (HD UP)	<input checked="" type="checkbox"/> NO	/	YES
6	KEY BUZ ACT	<input checked="" type="checkbox"/> YES	/	NO
7	VRM UNIT	<input checked="" type="checkbox"/> NM ↔ KM	/	NM ↔ SM
8	SCAN STOP	<input checked="" type="checkbox"/> STBY	/	TX
PROGRAM NO : 0357053-05				
ROM CHECK OK				
RAM CHECK OK				

TOTAL ON TIME = 000019 : 55
TOTAL TX TIME = 000010 : 09

APPENDIX C INSTALLING THE GC-1 GYRO CONVERTER

The Gyro Converter used to supply the gyro signal to the FR-1500D(A) radar series may be either the AD-10S or the newly developed GC-1.

The GC-1 is smaller than the AD-10S and can be fitted inside the display unit of the radar.

SUPPLIED MATERIALS

1. Gyro Interface Board 03P6856
2. Installation Materials
3. Spare Parts

INSTALLATION MATERIALS

No.	Name	Type	Code No.	Q'ty	Use
1	TF Capacitor	ECQ-V1H104JZW (0.1uF)	000-105-967	3	signal input averaging
2	Crimp-on Lug	FV5.5-4	000-538-123	1	grounding gyro connection cable shield
3	Crimp-on Lug	FV1.25-M3	000-538-110	6	core of gyro connection cable
4	Pan Head Screw	M3x8, C2700W MBNI2	000-881-404	6	Spacer & Gyro I/F Bd.
5	Pan Head Screw	M4x8, C2700W MBNI2	000-881-445	2	Spacer & Gyro I/F Bd.
6	Spacer (2)	HSA-3010	000-803-010	3	Gyro I/F Bd.
7	Label (GS)	03-024-9001	100-074-400	1	

SPARE PARTS

No.	Name	Type	Code No.	Q'ty	Use
1	Fuse	FGBO 0.5A AC250V	000-549-018	1	F1
2	Fuse	FGBO 1A AC250V	000-549-019	2	F2, F3

MODIFYING THE GC-1

The Gyro Interface Board 03P6856 of the GC-1 must be set to match the repeater signal of the connected gyrocompass. The gyrocompass specifications listed in the table below are compatible with the GC-1.

Item	Gyrocompass Specifications
Type of Repeater Signal	AC synchro/DC step
A. AC Synchro	
I) primary winding voltage	() VAC
II) secondary winding voltage	() VAC
III) frequency	50/60Hz / 400/500Hz
IV) ratio	360X/90X/36X (see note below)
B. DC Step	
I) repeater drive circuit	4-line DC ON-OFF signal/ 5-line open collector TR drive circuit
II) operating voltage	() VDC
III) ratio	180X
IV) level of common terminals	(+) / (-)

An AC synchro gyrocompass having a gyro ratio of 180X cannot be connected to the GC-1. The gyrocompass using this type of signal must be connected to Gyro Converter AD-10S.

The Gyro Interface Board 03P6856 is factory-set to accommodate the following gyrocompass.

signal type: AC synchro
 primary and secondary winding voltages: 100V
 frequency: 50/60Hz
 ratio: 90X

If the specifications of the gyrocompass and the factory-set specifications differs, refer to the tables on pages C-3, C-4, and C-5 and make the necessary modifications.

AC Synchro Type

Gyro Make	Spec.	Jumper Connection					Dip Switch S1 *6								
		Jump1 *1	Jump3 *2	Jump5 *3	Jump7 *4	Jump2,4,6 *5									
ANSCHUTZ : STANDARD1~6 HOKUSHIN PLATH : A, B-55, C-1, C-1A, C-2, C-3 PLATH : NAVGAT II~III MICROTECHNICA : LK-2, MB-12, MV-58	50/60VAC 50/60Hz (x360)						<table border="1" style="margin-left: auto; margin-right: auto;"> <tr><td>1</td><td>ON</td></tr> <tr><td>2</td><td>OFF</td></tr> <tr><td>3</td><td>ON</td></tr> <tr><td>4</td><td>OFF</td></tr> </table>	1	ON	2	OFF	3	ON	4	OFF
1	ON														
2	OFF														
3	ON														
4	OFF														
HOKUSHIN PLATH : CMZ-100, CMZ-200 C-Jr, D-1Z	100VAC 50/60Hz (X360)						<table border="1" style="margin-left: auto; margin-right: auto;"> <tr><td>1~4</td><td>ALL "OFF"</td></tr> </table>	1~4	ALL "OFF"						
1~4	ALL "OFF"														
MICROTECHNICA : SIRIUS	115VAC 60Hz (X360)						<table border="1" style="margin-left: auto; margin-right: auto;"> <tr><td>1</td><td>ON</td></tr> <tr><td>2</td><td>OFF</td></tr> <tr><td>3</td><td>ON</td></tr> <tr><td>4</td><td>OFF</td></tr> </table>	1	ON	2	OFF	3	ON	4	OFF
1	ON														
2	OFF														
3	ON														
4	OFF														
TOKYO KEIKI SPERRY : ES-1, ES-2, ES-11, GLT-101/102/103/ 106K	110VAC 60Hz (X36)						<table border="1" style="margin-left: auto; margin-right: auto;"> <tr><td>1</td><td>ON</td></tr> <tr><td>2</td><td>OFF</td></tr> <tr><td>3</td><td>ON</td></tr> <tr><td>4</td><td>OFF</td></tr> </table>	1	ON	2	OFF	3	ON	4	OFF
1	ON														
2	OFF														
3	ON														
4	OFF														
TOKYO KEIKI SPERRY : ES-11A, TG-200, PR237L,H	110VAC 60Hz (X90)						<table border="1" style="margin-left: auto; margin-right: auto;"> <tr><td>1</td><td>ON</td></tr> <tr><td>2</td><td>OFF</td></tr> <tr><td>3</td><td>ON</td></tr> <tr><td>4</td><td>OFF</td></tr> </table>	1	ON	2	OFF	3	ON	4	OFF
1	ON														
2	OFF														
3	ON														
4	OFF														
SOVIET UNION : BEGA, KURS-4 AMUR-3	110VAC 50Hz (X360)						<table border="1" style="margin-left: auto; margin-right: auto;"> <tr><td>1</td><td>ON</td></tr> <tr><td>2</td><td>OFF</td></tr> <tr><td>3</td><td>ON</td></tr> <tr><td>4</td><td>OFF</td></tr> </table>	1	ON	2	OFF	3	ON	4	OFF
1	ON														
2	OFF														
3	ON														
4	OFF														
SOVIET UNION : AMUR-M	110VAC 500Hz (X360)						<table border="1" style="margin-left: auto; margin-right: auto;"> <tr><td>1</td><td>ON</td></tr> <tr><td>2</td><td>OFF</td></tr> <tr><td>3</td><td>ON</td></tr> <tr><td>4</td><td>OFF</td></tr> </table>	1	ON	2	OFF	3	ON	4	OFF
1	ON														
2	OFF														
3	ON														
4	OFF														

NOTE

- *1. Change jumper to match input voltage.
- *2. Change jumper to match gyro signal frequency.
- *3. Connect for synchro type.
- *4. Bearing data output rate switchover. (25ms/200ms)
- *5. Not used for synchro type.
- *6. Change setting to match gyro ratio.

The GC-1 Gyro Converter cannot be connected to an AC synchro gyrocompass whose gyro ratio signal is 180X.

DC Step Type

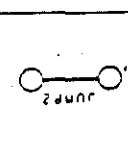
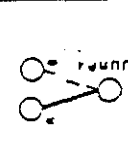
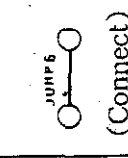
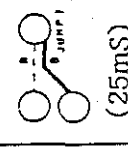
Gyro Make	Spec.	Jumper Connection					Dip Switch S1 *5								
		Jump2 *1	Jump4 *2	Jump6 *1	Jump7 *3	Jump1,3,5 *4									
TOKYO KEIKI SPERRY: MK-14 MOD-1, MK-14 MOD-2, MK-14 MOD-1, MK-EN, MK-EI	70VDC 3 wire (+) and common line (X180)	 (Connect)	 (Connect)	 (Connect)	 (25mS)	(Don't Connect)	<table border="1"> <tr><td>1</td><td>ON</td></tr> <tr><td>2</td><td>ON</td></tr> <tr><td>3</td><td>ON</td></tr> <tr><td>4</td><td>ON</td></tr> </table>	1	ON	2	ON	3	ON	4	ON
1	ON														
2	ON														
3	ON														
4	ON														

NOTE: For connections to the gyro of which the potential of the common line is higher than that of the stator (e.g., TOKYO KEIKI SPERRY TG-5000, ARMABROWN MK-10, etc.), the step voltage is not 35V or 70V (e.g., FURUNO GY-700 etc.), or the capacity of the output circuit of the gyrocompass is insufficient to make the gyro interface operative, use an external power supply. See page C-9.

NOTE

- *1. Connect for synchro type.
- *2. Change jumper to match input voltage.
- *3. Bearing data output rate. (25ms/200ms)
- *4. Not used for synchro type.
- *5. Change setting to match gyro ratio.

When combining with a step-by-step gyrocompass whose repeater signal employs a pulsating current rectified in half-wave or full wave, put three capacitors (0.1uF, supplied as installation materials) and a resistor (22k, locally supplied) on the Gyro Converter board (03P6856).

If this modification is not satisfactory change the capacity of the capacitors to 0.33uF.

Modification for Gyrocompasses not listed on pages C-3 or C-4

A) Modification according to signal type (AC synchro/DC step)

Jumper No.	AC synchro type	DC step type (*)
JUMP 1	Connect referring to B)	Not connected (open)
JUMP 2	Not connected (open)	Connected
JUMP 3	Connect referring to C)	Not connected (open)
JUMP 4	Not connected (open)	Connect referring to B)
JUMP 5	Connected	Not connected (open)
JUMP 6	Not connected (open)	Connected
JUMP 7	Connect to B side (25ms)	

* If the step voltage is 30V or less, the potential of the common line is higher than that of the stator, or the repeater output circuit capacity is insufficient, see page C-9.

B) Modification according to input voltage

Signal type	AC synchro type			DC step type	
Jumper No.	JUMP 1			JUMP 4	
Input voltage	AC25V	AC50V	AC100V	DC35V	DC70V
Jumper connection					

↑
factory setting

C) Modification according to frequency (AC synchro type)

Frequency	50/60 Hz	400/500Hz
Jumper connection JUMP 3		

↑
factory setting

D) Setting DIP switch S1 according to gyro ratio

Signal type		AC synchro type						DC step type
		50/60Hz			400/500Hz			
Gyro ratio		360X	90X	36X	360X	90X	36X	180X
DIP switch S1	#1	ON	ON	OFF	ON	ON	OFF	ON
	#2	OFF	OFF	OFF	ON	ON	ON	ON
	#3	ON	OFF	OFF	ON	OFF	OFF	ON
	#4	OFF	OFF	OFF	OFF	OFF	OFF	ON

↑
factory setting

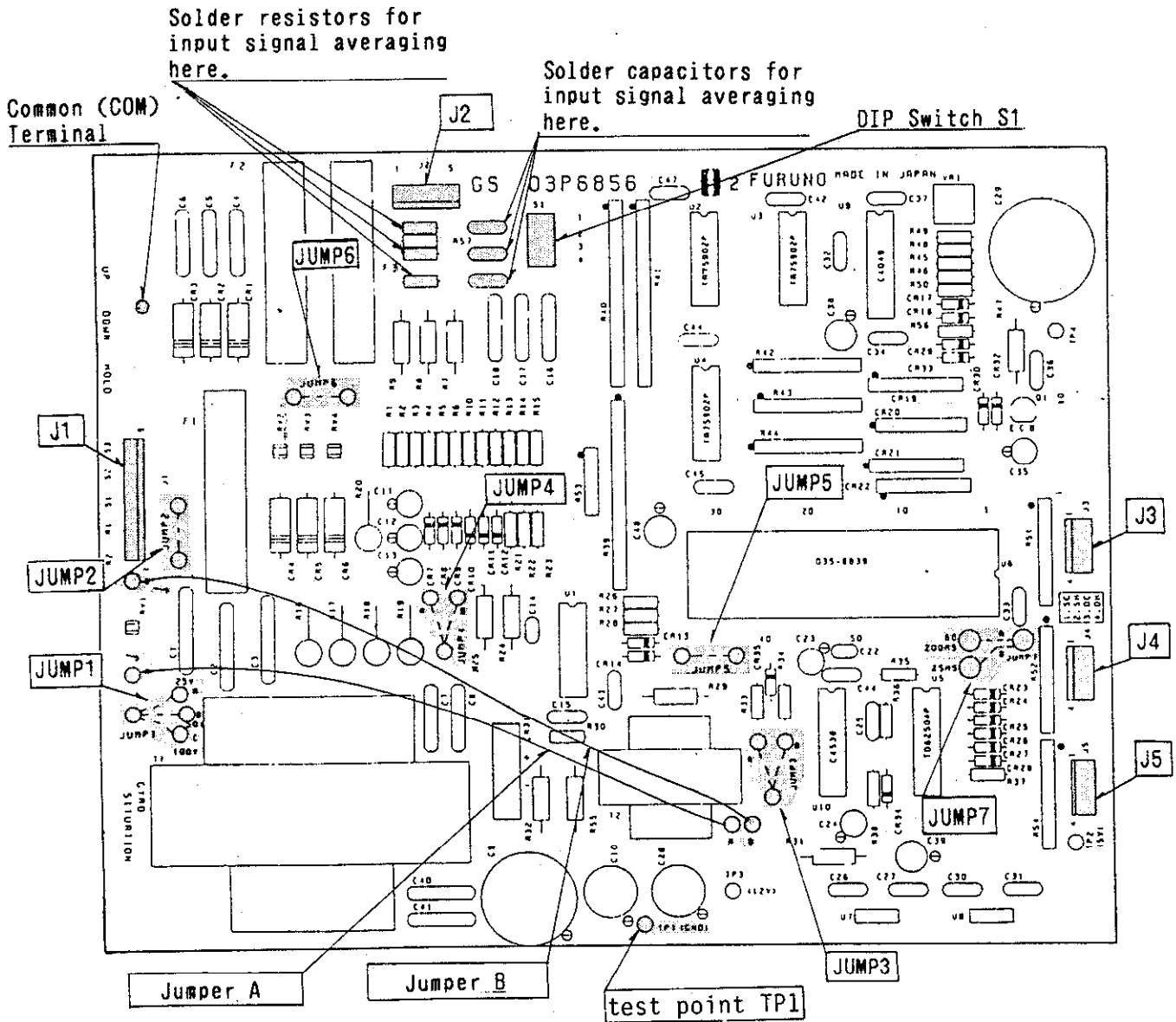

Fig. C-1 Location of Jumpers, etc. on the Gyro Interface Board

INSTALLING THE GYRO CONVERTOR BOARD

Fix the Gyro Converter Board to the Display Unit of the FR-1500D(A) radar as shown below.

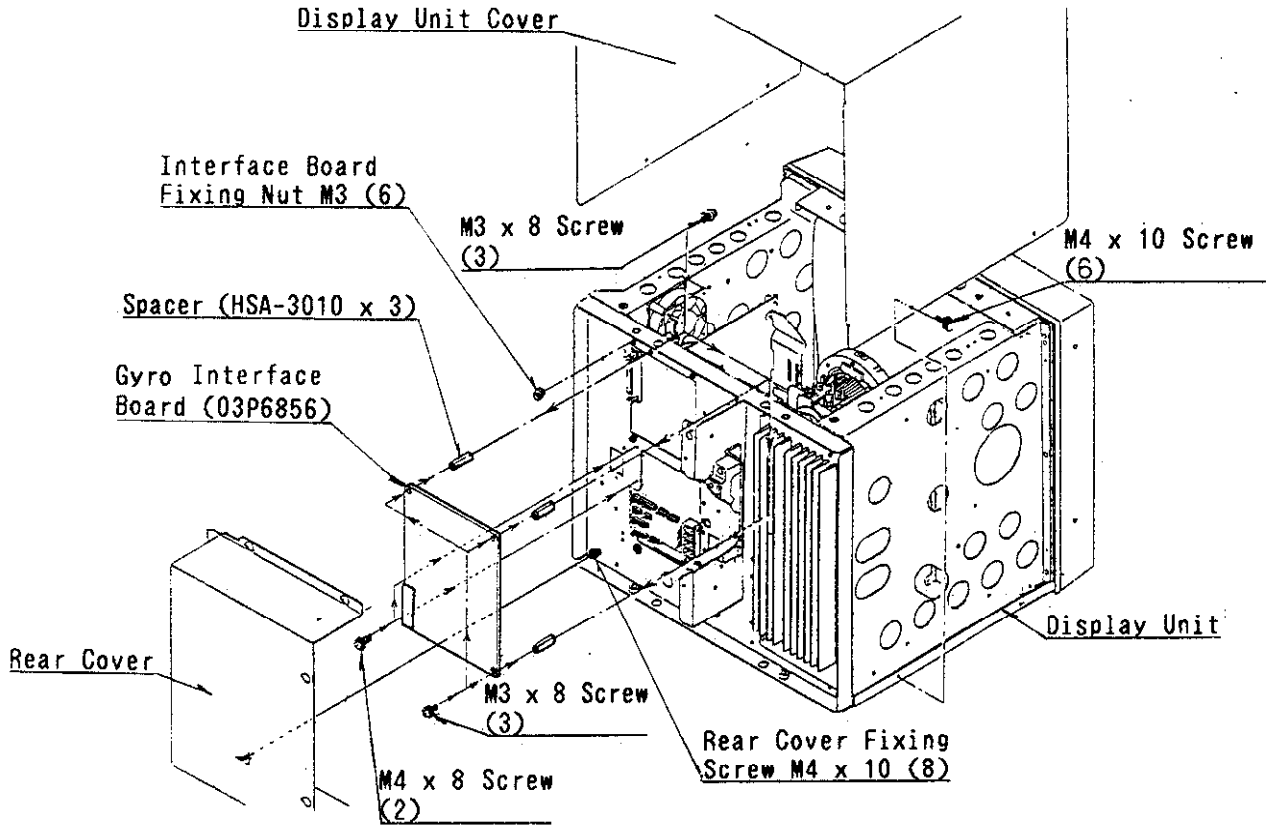

Fig. C-2 Fixing the Gyro Interface Board to the Display Unit.

1. Loosen the six M4x10 screws fixing the display unit cover.
2. Loosen the eight M4x10 screws securing the rear cover to the display unit.
3. Fix the three spacers (HSA-3010) to the rear of the display unit with three M3x8 screws as illustrated above. Since one of the screw holes for a spacer is blocked by the Interface Board 03P6980, loosen the six nuts fixing the board, realign the board, and then fix the spacer. Refix the board.
4. After fixing the Gyro Interface Board to the spacers with three M3x8 screws, fix it to the display unit with the two M4x8 screws.
5. Connect the three connectors from the Interface Board to the Gyro Interface Board as shown below.

Interface Board	J18	J19	J20
03P6856 Board	J1	J3 or J4 J5	J2

6. Attach the label supplied to the outside of the rear cover. Refix the cover after completing the wiring.

WIRING

Fabricate the 5-core cable (MPYCS-5, or similar type) from the gyrocompass as shown below and connect it to J17 on the Interface Board (03P6980). Ground the armor of the cable with a cable clamp. Likewise, ground the shield to the rear chassis by one of the M4x8 screws fixing the Gyro Interface Board.

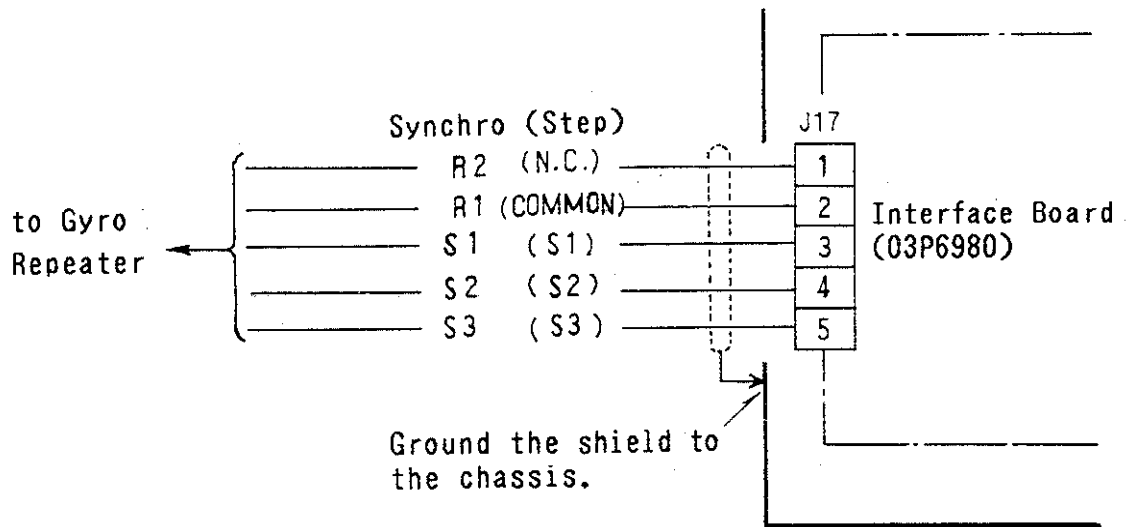

Fig. C-3 Connecting the 5-core Cable

Fabricating the 5-core Cable

1. Cut the cable to a suitable length.
2. Cut off about 120mm of the armor and vinyl sheath.
3. Expose the core by spreading out the mesh, using a slotted-head screwdriver.
4. Cut off 10mm of the shield; and then solder a ground wire to it.
5. Wrap vinyl tape around the armor, vinyl sheath and ground wire.
6. Fit a crimp-on-lug to each core (crimp-on lug: FV1.25-M3) and the shield (crimp-on lug: FV5.5-4)

NOTE: Ground the armor with a cable clamp.

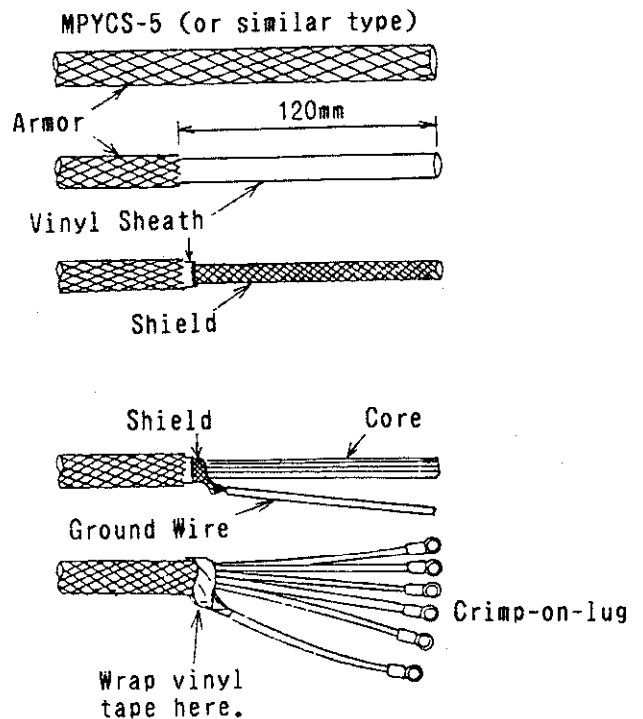

Fig. C-4 Fabricating the 5-core Cable

When the step voltage is too low (DC step type), the potential of the common line is higher than that of the stator, or the repeater output circuit capacity is insufficient (logic level, etc.).

To connect these types of gyrocompasses to the GC-1, a 25/50/100VAC or 24/32VDC external power source is required. In addition, the following modifications must be made.

1. Jumper Connection on the Gyro Interface Board 03P6856

JUMP1	For an external AC power source. Connect according to voltage of external power source (25V, "A"; 50V, "B" and 100V, "C") For an external DC power source Cut JUMP1
JUMP 2 thru 6	Cut all jumpers
JUMP7	Set "B" side to 25mS

2. Cut jumper wires A and B on the Gyro Interface Board.
3. Set DIP switch S1 for a gyro ratio of 180X, referring to the table on page 2-13.
4. Following the diagram Fig C-5(a) or C-5(b), connect both the 5-core cable from the gyrocompass and the cable from the external power source.

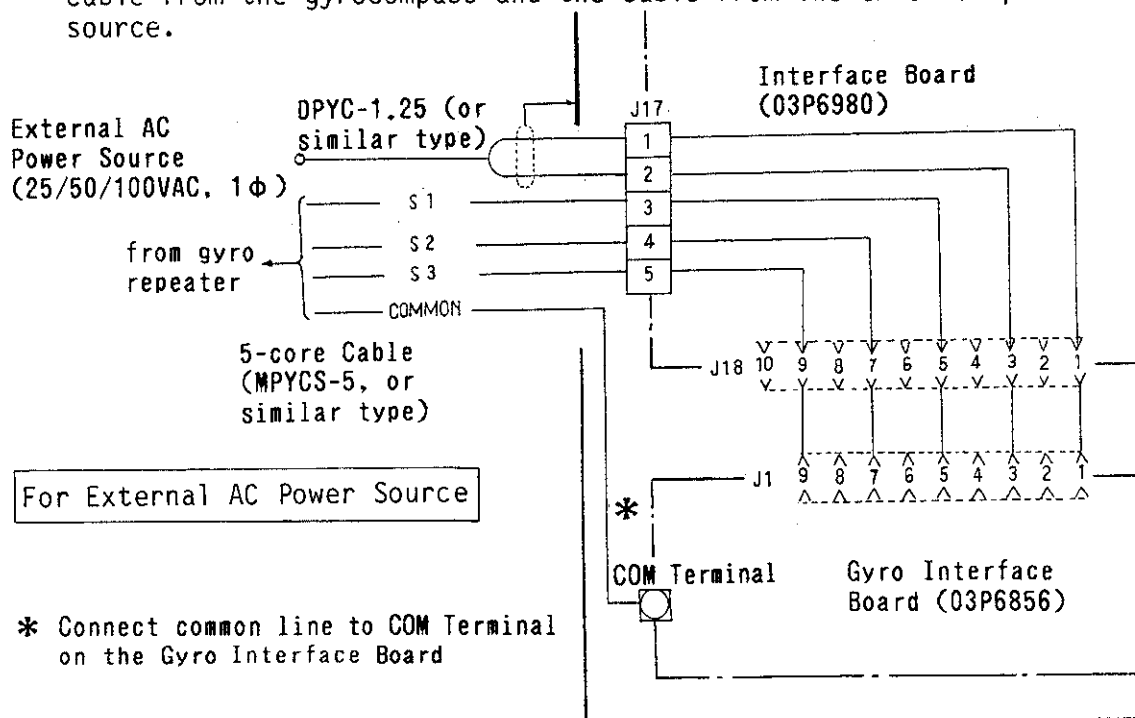
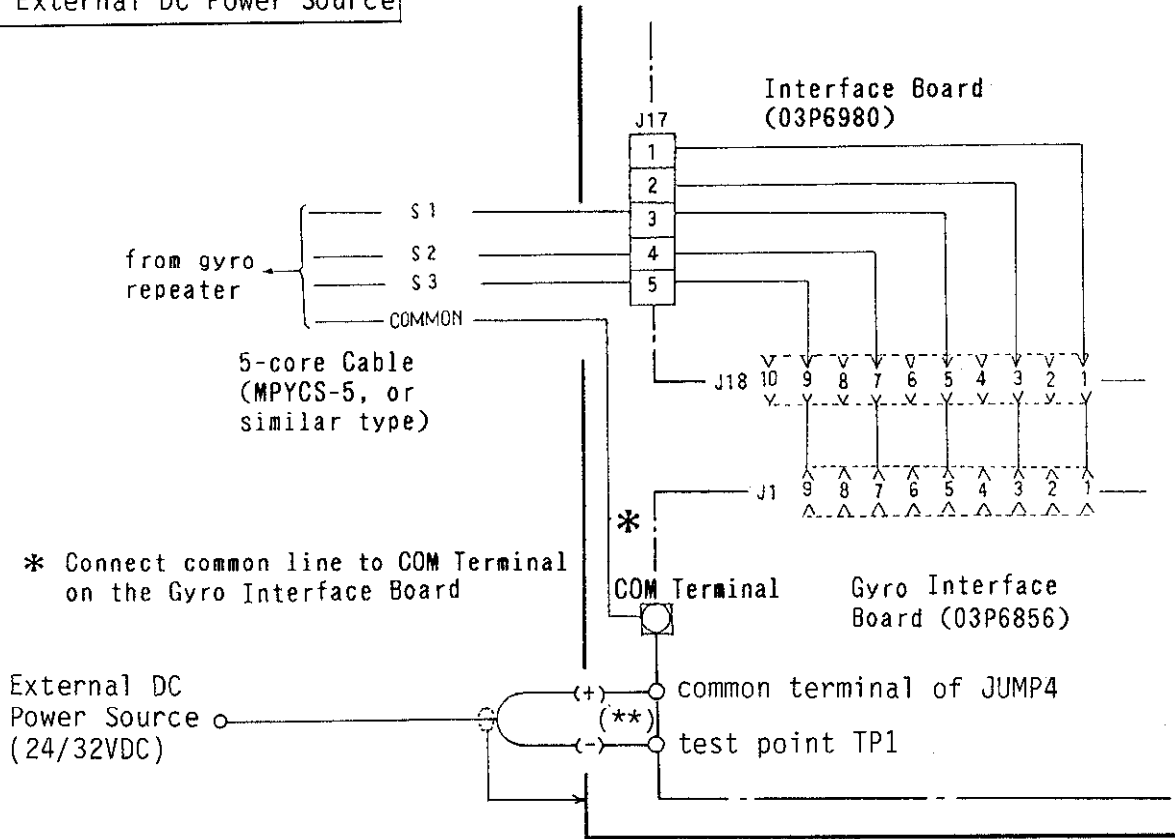

Fig. C-5(a) Connecting the 5-core Cable and External AC Power Source Cable

For External DC Power Source



* Connect common line to COM Terminal on the Gyro Interface Board

External DC Power Source (24/32VDC)

(**) Solder the power source line to common terminal of JUMP4 (+) and test point TP1 (-).

Fig. C-5(b) Connecting the 5-core Cable and External DC Power Source Cable

APPENDIX D ALTERATION OF RANGE UNITS FROM NM (NAUTICAL MILES) TO SM (STATUTE MILES)

The units of range can be altered from NM to SM by replacing the crystal oscillator and the system program ROM.

Necessary Parts (Statute Mile Kit)

PROM : Program No. 0357440-100
Crystal Oscillator : TCO-711A 78.240 MHz

Replace U15 (PROM) and U107 (crystal oscillator).

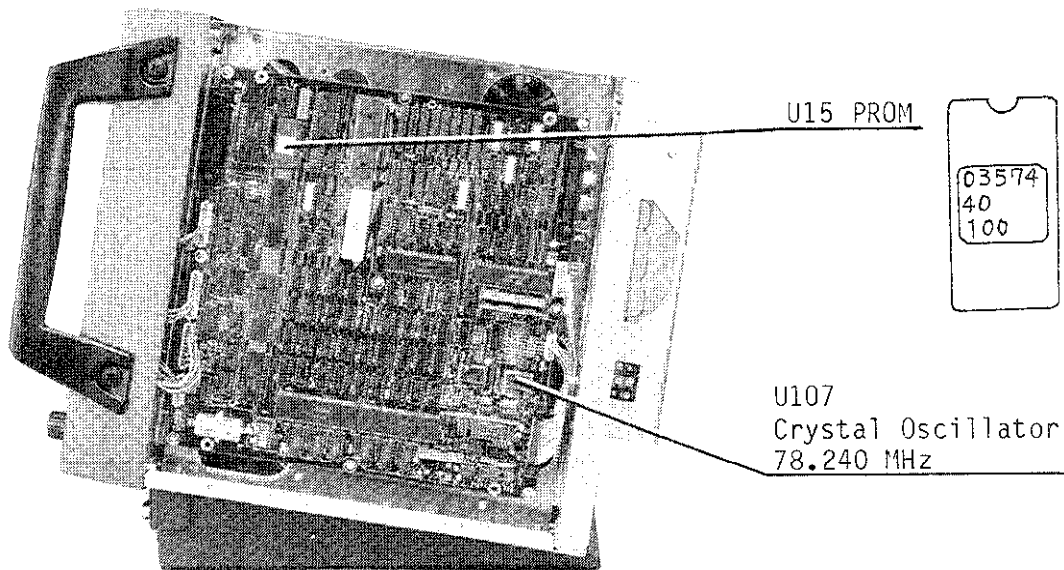

N Photo No.2300

NOTE:

When the above modification is carried out, the following points will differ from the standard version.

1. Video Plotter RP-1 cannot be connected.
2. Stern mark is indicated by a dotted line.

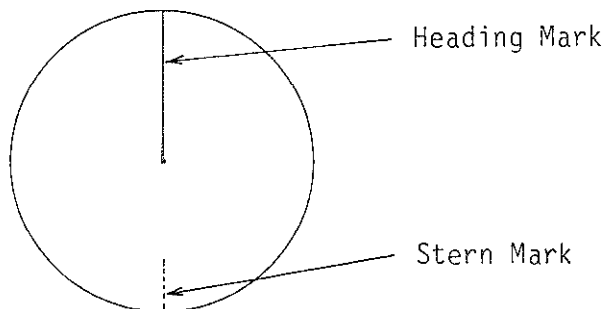

3. VRM UNIT and PROGRAM NO in the initial message screen are displayed as below.

DIP SWITCH		OFF	/	ON
1		<input checked="" type="checkbox"/> MASTER	/	SLAVE
4	P.MONITOR INST	<input checked="" type="checkbox"/> NO	/	YES
5	EAV12 ACT (HD UP)	<input checked="" type="checkbox"/> NO	/	YES
6	KEY BUZ ACT	<input checked="" type="checkbox"/> YES	/	NO
7	VRM UNIT	<input checked="" type="checkbox"/> SM ↔ NM	/	SM ↔ KM
8	SCAN STOP	<input checked="" type="checkbox"/> STBY	/	TX
PROGRAM NO : 0357440-00 ROM CHECK OK RAM CHECK OK				

TOTAL ON TIME = 000719 : 55
TOTAL TX TIME = 000010 : 09

APPENDIX E MODIFICATION TO CHANGE THE ANTENNA IN LENGTH

This radar is so designed that the 123cm and 200cm antenna are driven by the inverter unit, while the 240cm antenna is driven directly by 24VDC mains. The following modification is required in the display unit in order to change the antenna in length from 123cm or 200cm type to 240cm type, or vice versa.

- 1) Remove the power supply module.
- 2) Solder the jumper on the Rectifier board (PTU-6982) according to the illustration below.
- 3) Reinstall the power supply module.

NOTE: There is no difference between the interconnecting cable for the 123cm, 200cm and 240cm radiator.

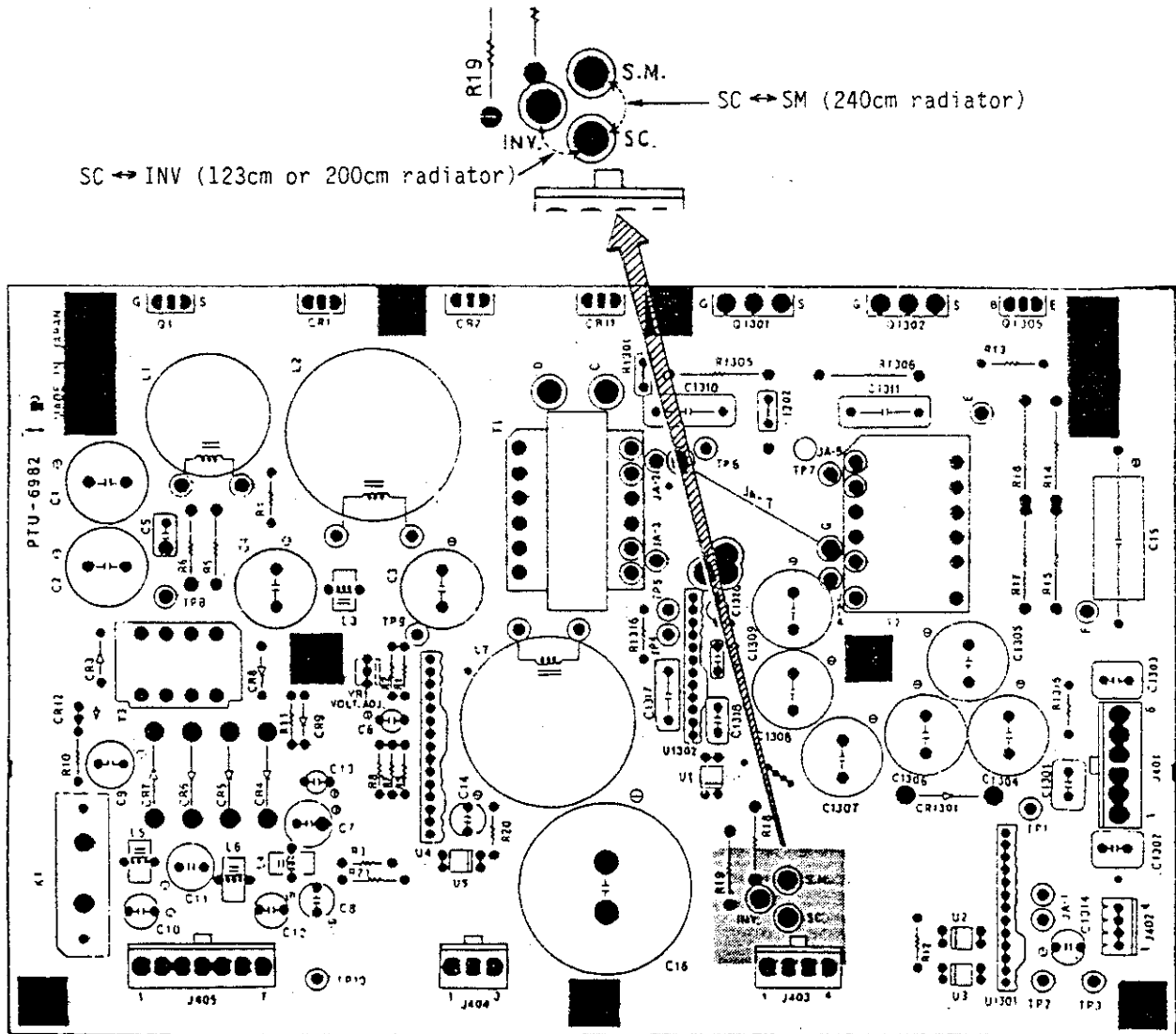

Fig. E-1 Power Supply Board, Parts Side

Parts shown below are required for this modification.

Parts List

No.	Name	Type	Code No.	Q'ty	Remarks
1	Relay	VF12HN	000-108-676	1	
2	Diode	1S2095A	000-113-046	1	
3	Washer Head Screw (A)	M3x10 C2700W MBNI2	000-881-105	2	For mounting relay
4	Hex. Nut	M3 C2700W MBNI2	000-863-204	2	
5	Flat Washer	M3 C2700W MBNI2	000-864-104	2	
6	Lead Wire	UL1007 (or equal)		Approx. 70cm	

- 4) Remove the display cover by loosening six M4x10 cosmetic screws.
- 5) Remove the rear cover by loosening eight M4x10 screws.
- 6) Remove the six M3 hex. nuts secured the Interface board (03P6980) to the display chassis.
- 7) Unplug the connectors connected to the Interface board, and then remove the board.

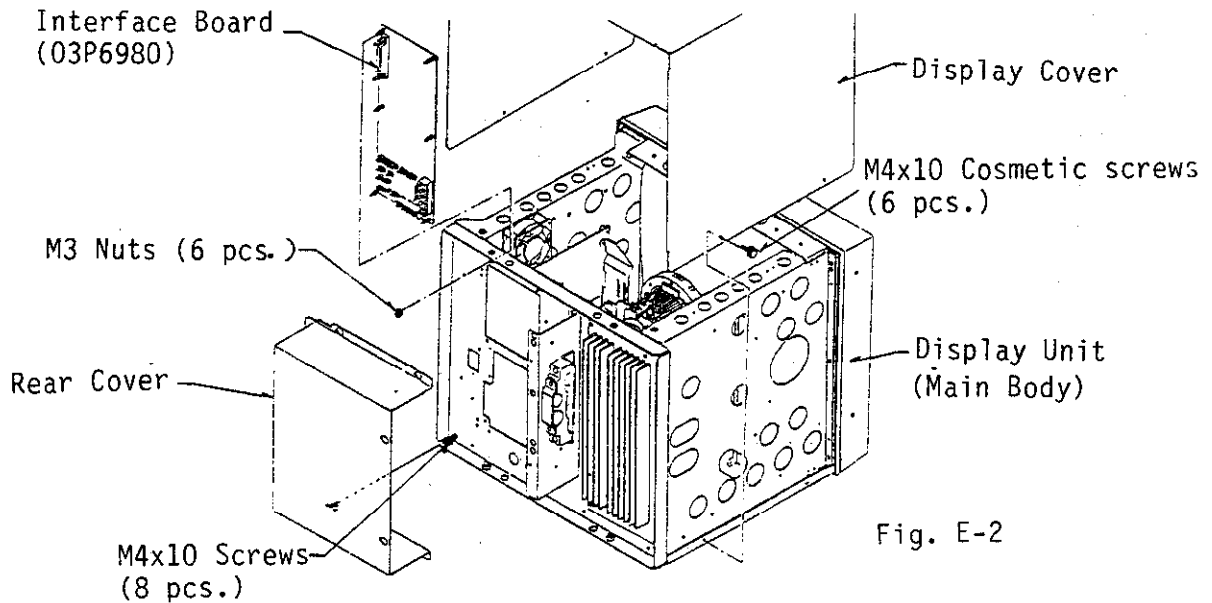

- 8) Solder the two jumper connections and the three wires (approx. 20cm long) to the Interface board. See fig. E-3.

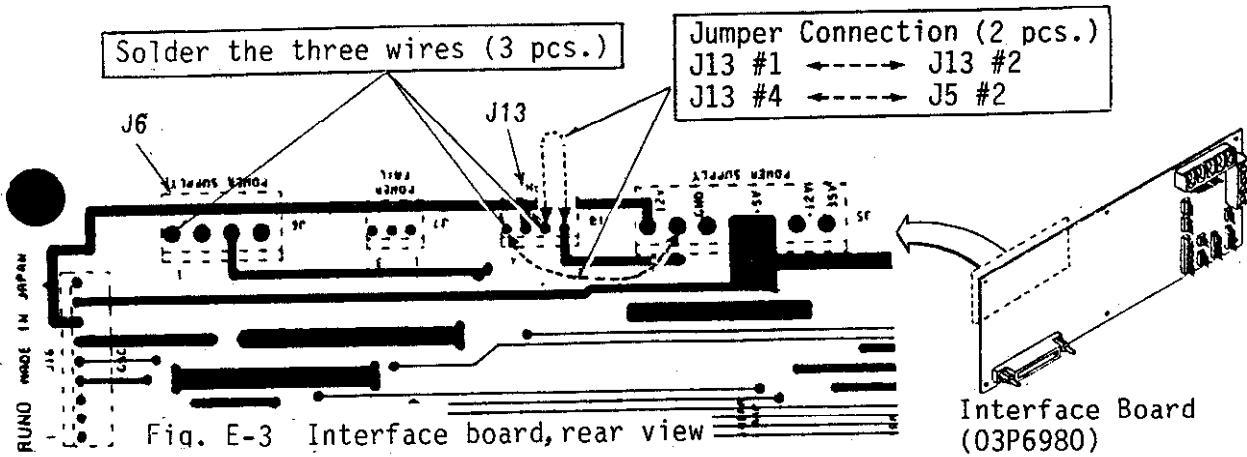

9) Make two $\phi 3.1$ holes on the display rear chassis. See fig. E-4(a).

NOTE: These holes are factory-drilled for the sets produced after Sep. 1987.

Serial No.
 FR-1510D --- 344-0043 and after, FR-1510DA --- 345-0111 and after
 FR-1525D --- 346-0031 and after, FR-1525DA --- 347-0056 and after

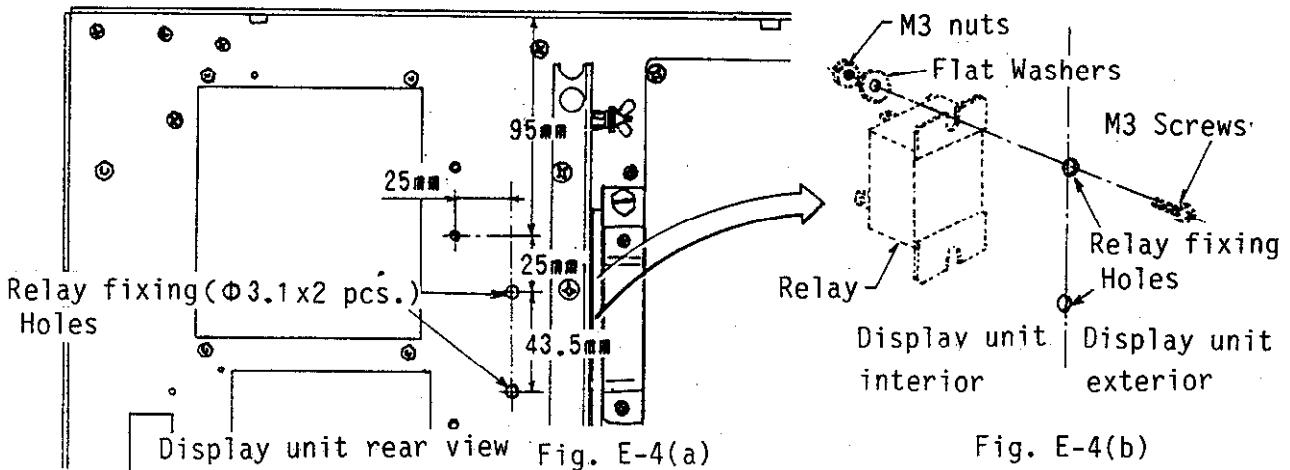

10) Remove the brown wire from the connector P6-#1; solder this wire to the COM terminal on the relay (VF12HN). Solder to the relay the three wires soldered to the Interface board at step 8, referring to fig. E-5. Solder the diode (1S2095A) to the relay referring to fig. E-5.

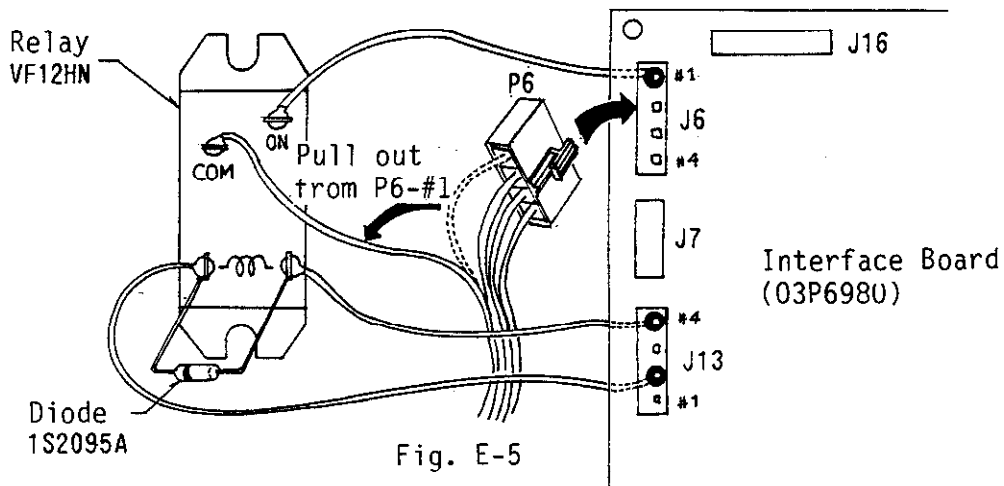

- 11) Check that the wiring conforms to fig. E-6. Fix the relay by the two M3 screws, flat washers, and nuts referring to fig. E-4(b).

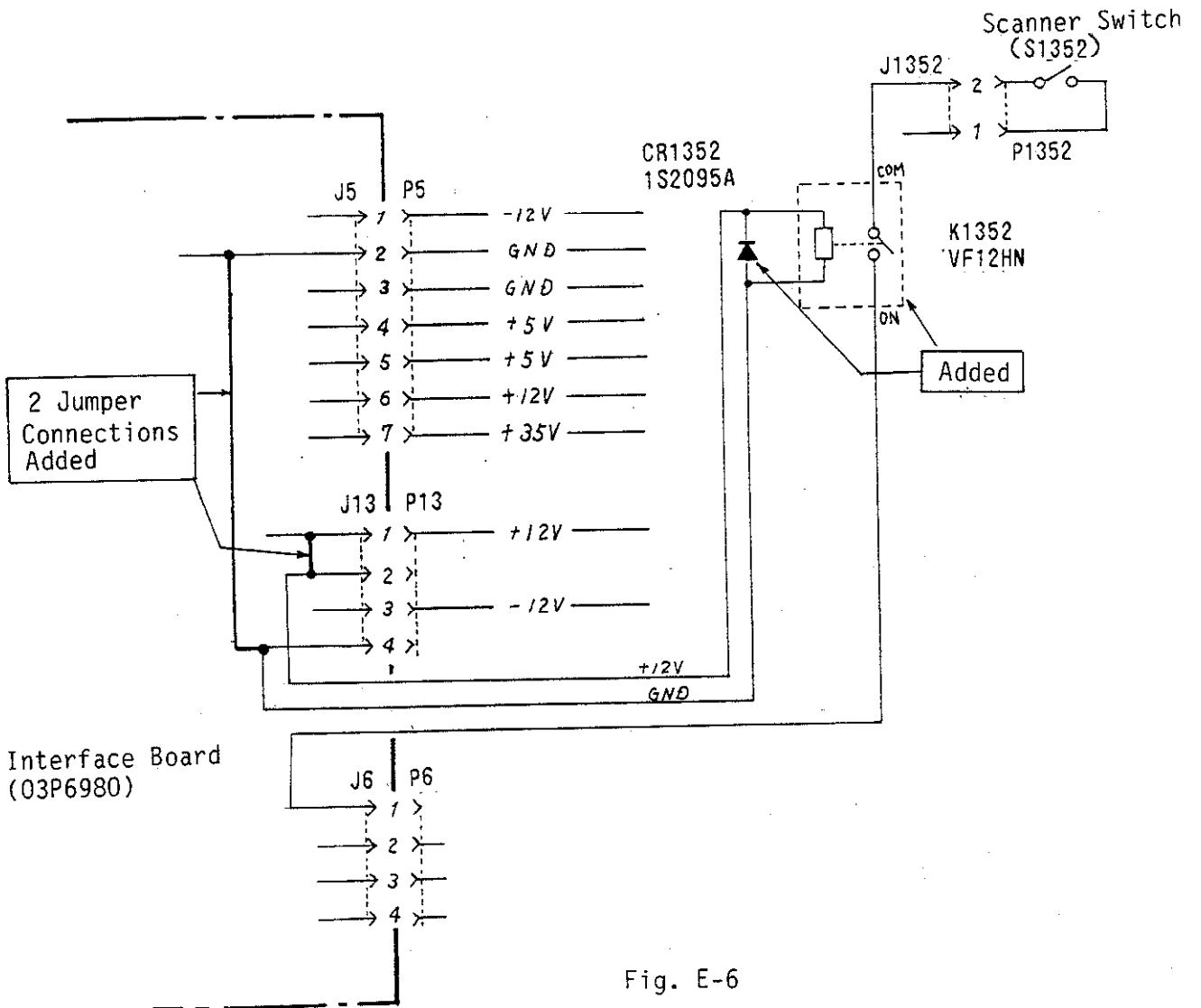
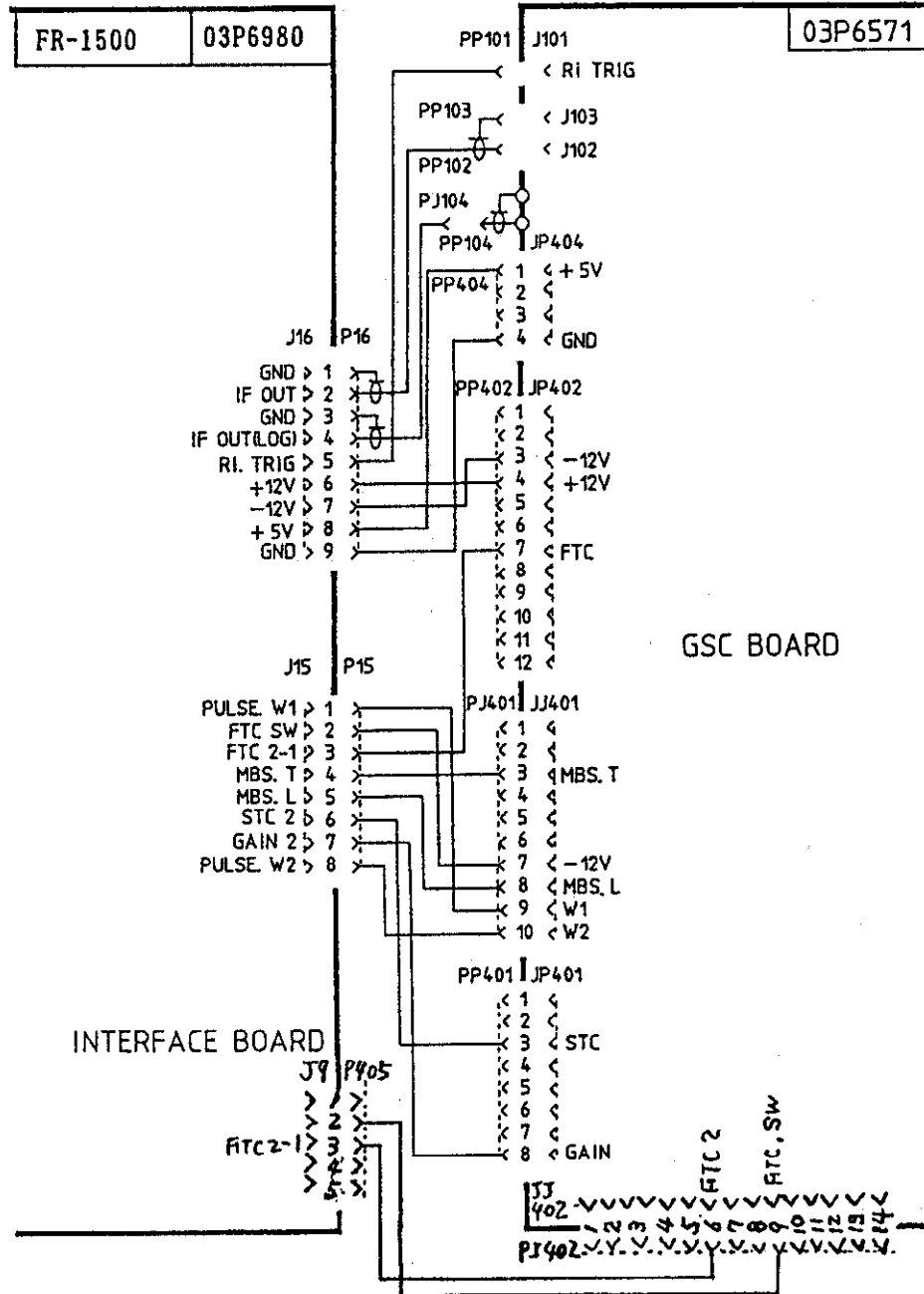

Fig. E-6

APPENDIX F GSC BOARD CONNECTION FOR LOG AMP TYPE



LIST OF SCHEMATIC DIAGRAMS

No.	Item	Type	Dwg. No.	Page	Remarks
1	Display Unit		C3307-007	S-1	
2	Power Supply Board	PTU-6982	C3307-006	S-2	
3	Interface Board	03P6980	C3307-010	S-3	
4	Panel Board	03P6978	C3307-012	S-4	
5	EBL/VRM Board	03P6981	C3307-008	S-5	
6	CRT Display	TR-1523X9A	C3307-021	S-6	
7	TX HV Board	BHV-7130	C3307-005	S-7	
8	Gyro Interface Board	GC-1 (03P6856)	C3307-009	S-8	option
9	GSC Board	03P6571	C3291-014	S-9	Log Amp type
10	Scanner Unit		C3307-013 C3307-016 C3314-K03	S-10a S-10b S-10c	D-type DA-type Log Amp type
11	STC Board	ASTC-6995 BSTC-6995	C3307-011	S-11	DA-type D-type
12	IF Amplifier Board	BIF-4879 BIF-5668 03P6570	C3314-K01 C3307-014 C3291-006	S-12a S-12b S-12c	D-type DA-type Log Amp type
13	MBS Board	03P6569	C3291-003	S-13	Log Amp type
14	Interconnection Diagram		C3307-023	5-12	

LIST OF OUTLINE DRAWINGS

No.	Item	Type	Dwg. No.	Page	Remarks
1	Scanner Unit		C3237-001	5-4	(XN-2/XN-3 radiator)
			C3249-011	5-5	(XN-3A/XN-4A radiator)
2	Display Unit		C3307-020	5-15	
3	Rectifier	RU-1746B-2	C3002-002	5-20	AC Mains

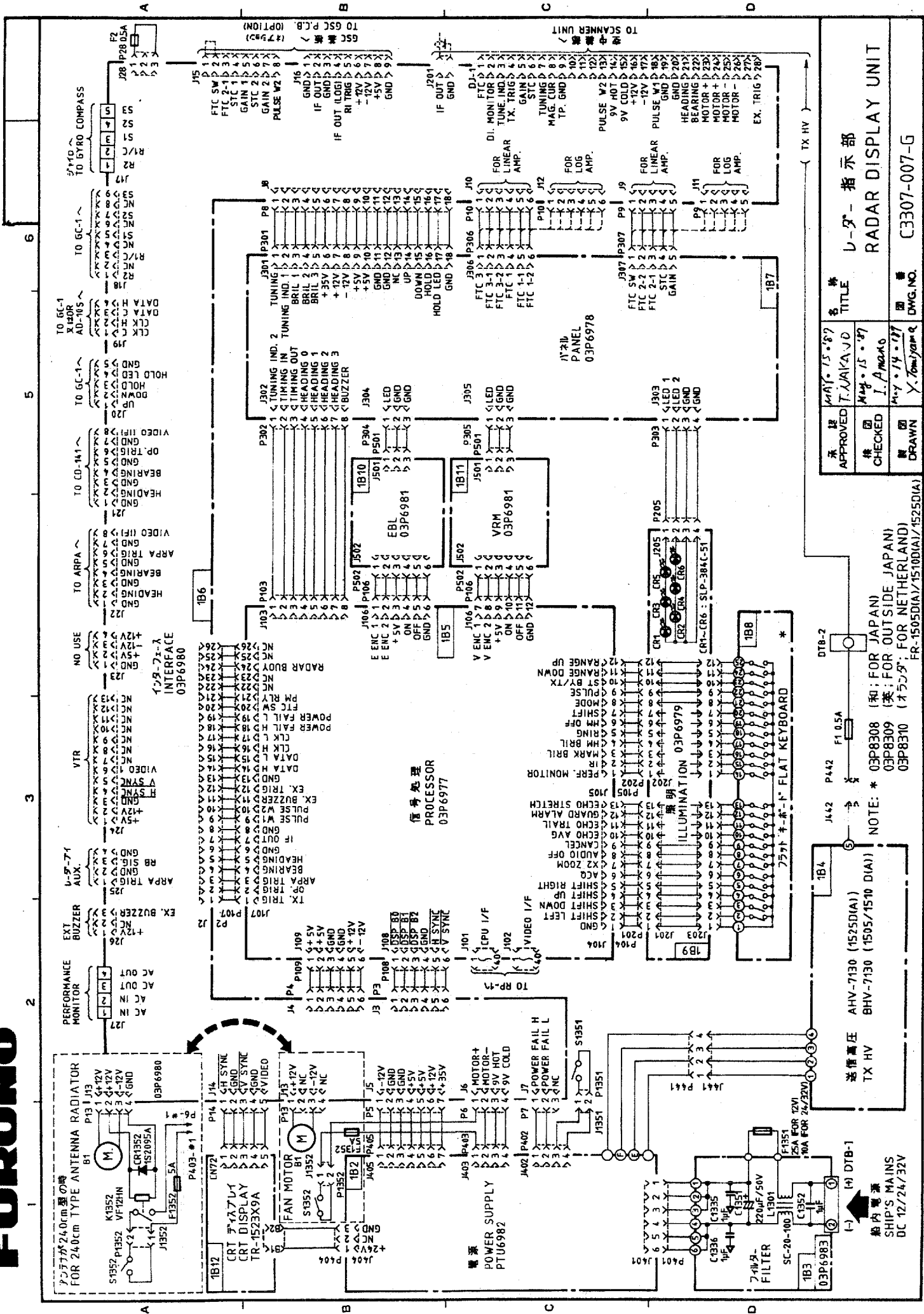

承認 APPROVED	May. 15. 87 T. Aikawa	名称 TITLE	シ-ダ- 指示部 RADAR DISPLAY UNIT
検閲 CHECKED	May. 15. 87 I. Amano	図番 DWG. NO.	C3307-007-G
製図 DRAWN	May. 14. 87 Y. Tomiyama		

送電高圧
TX HV

送電高圧
AHV-7130 (15250V IA1)
BHV-7130 (1505/1510 DIA1)

船内電源
SHIP'S MAINS
DC 12/24/32V

注意 * 03P8308 (和; FOR JAPAN)
03P8309 (英; FOR OUTSIDE JAPAN)
03P8310 (オランダ; FOR NETHERLAND)

FR-15050(A)/15100(A1)/15250(A1)

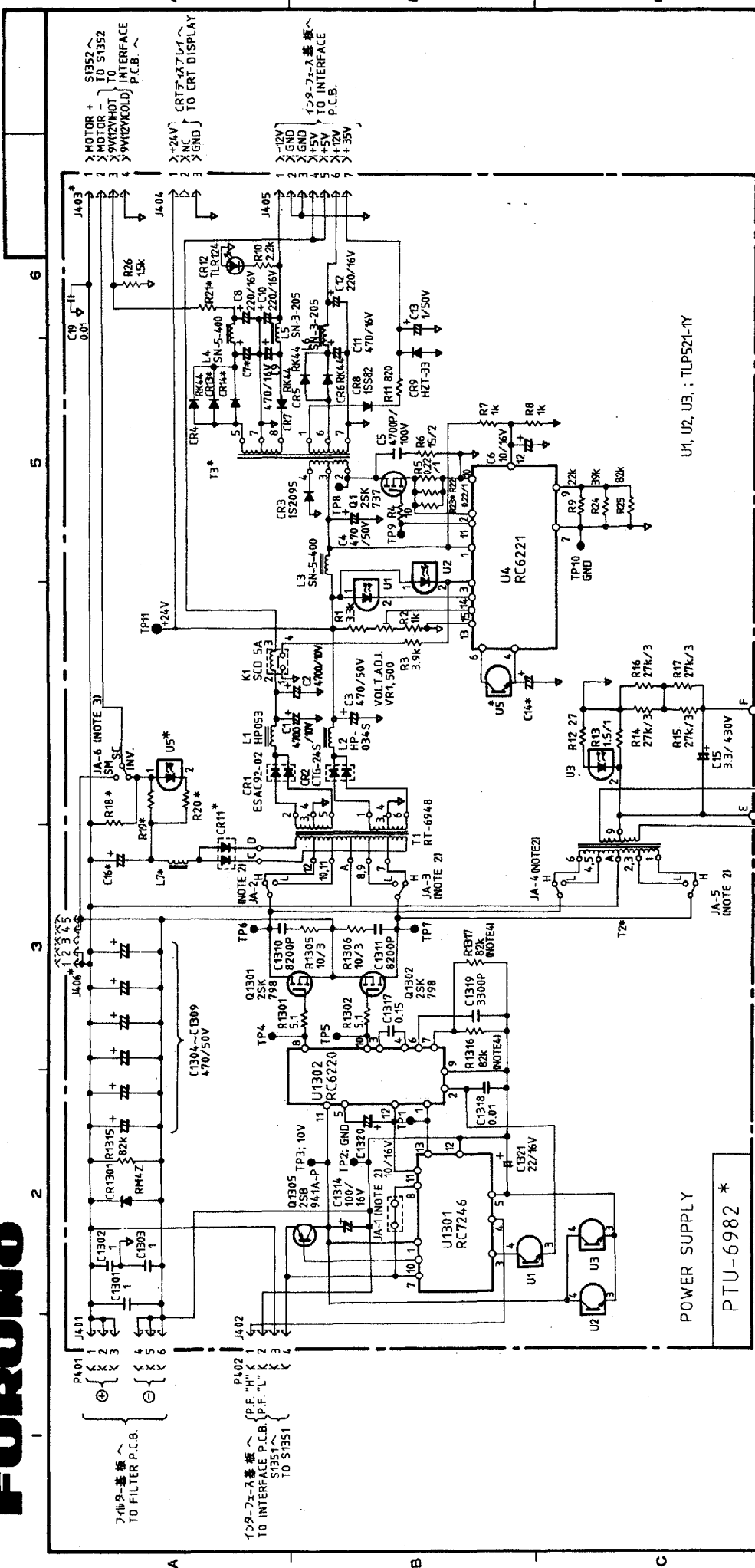

NOTE 5. *

NOTE 1. 特記なき抵抗の単位は全てΩ, 0.25W 又 コンデンサはμF.
ALL RESISTANCE IN OHMS, 0.25W, CAPACITANCE IN MICROFARADS UNLESS NOTED OTHERWISE.

NOTE 2. 電源仕様により右の様にジャンパを変える。
CHANGE JUMPER CONNECTIONS ACCORDING TO SHIP'S MAINS.

NOTE 3. 空中線型式により右の様にジャンパする。
CHANGE CONNECTION ACCORDING TO TYPE OF ANTENNA RADIATOR.

NOTE 4. インバータ発振周波数が23.63kHz以上の場合はR1317を別除。
REMOVE R1316 WHEN INVERTER FREQUENCY IS MORE THAN 23.63kHz.

インバータ発振周波数が21.38kHz以下の場合はR1317を追加。
R1317 IS USED ONLY WHEN INVERTER FREQUENCY IS LESS THAN 21.38kHz.

MODEL	PCB	C7	C14	C16	C18	CR11	CR14	L7	R18	R19
FR-1500D (A)	APTU-6982	470μ/16V	100μ/16V	4700μ/16V	4700μ/16V	CTG-24R	HP-024S	1.5K/2W	0.22/2W	
FR-1525D (A)	BPTU-6982	470μ/16V	100μ/16V	4700μ/16V	4700μ/16V	CTG-24R	HP-024S	1.5K/2W	0.22/2W	
FR-1510D (A)	BPTU-6982	1000μ/16V					RK44			
FR-1530D (A)	CPTU-6982	1000μ/16V					RK44			

MODEL	R20	R21	R23	T2	T3	U5	J403, #1, #2	J403, #4	J406
FR-1500D (A)	27	1/1W		RT-7128	RT-6651	TLPS21-1Y	MOTOR+, -	9V HOT, COLD	
FR-1525D (A)	27	1/1W		RT-7128	RT-6651	TLPS21-1Y	MOTOR+, -	9V HOT, COLD	
FR-1510D (A)				RT-7128	RT-6651	0.33/1W	RT-7128	RT-7128	12V HOT, COLD
FR-1530D (A)				SHORT					

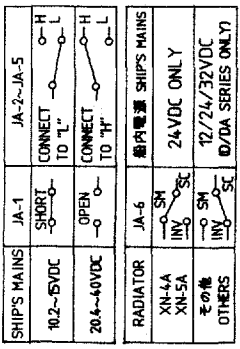

承認
APPROVED
検閲
CHECKED
製図
DRAWN
各務
TITLE
PTU-6982
I. Amano
Y. Kobayashi

電源部回路図
POWER SUPPLY
C3307-006-G

FR-1500D(S) SERIES
FR-1500D(A) SERIES

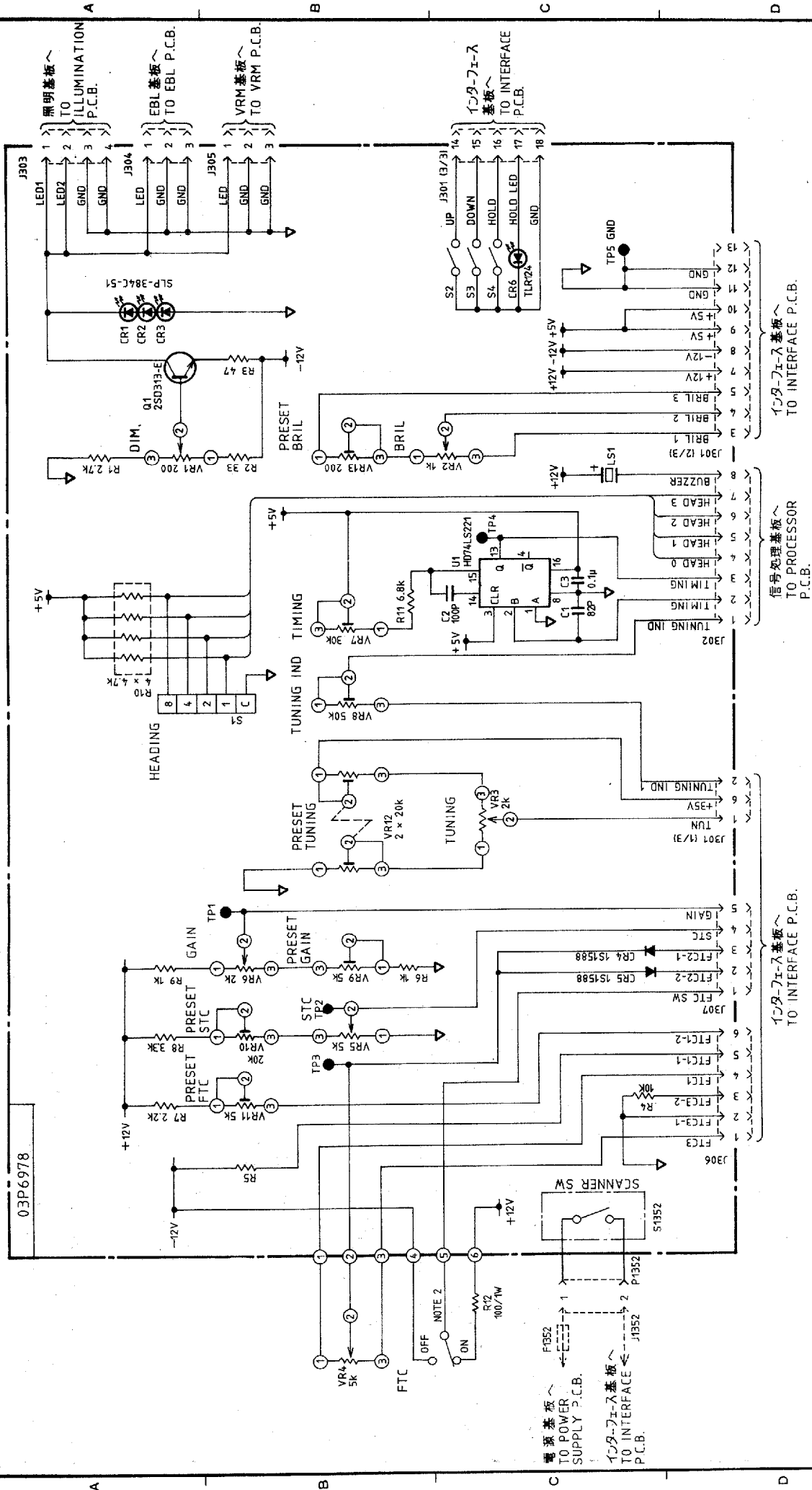

NOTE 1 特配なき抵抗の単位は全て0.025W 又 コンデンサはF.
 ALL RESISTANCE IN OHMS, 0.25W, CAPACITANCE
 IN FARADS UNLESS NOTED OTHERWISE.

2 FTCスイッチはFR-1500D(A)シリーズのみ使用。
 FTC SWITCH IS EFFECTIVE FOR FR-1500D(A) SERIES ONLY.

承認 APPROVED	May 21 '87 T. AKAHARA	名称 TITLE	03P6978 パネル基板 PANEL P.C.B.
検閲 CHECKED	May 21 '87 I. Amano	製図 DRAWN	
製図 DRAWN		製図 DWG. NO.	C3307-012-E

FR-1500DS SERIES
 FR-1500D (A) SERIES

A

2

3

C

D

(EBL) (VRM) P.C.B.

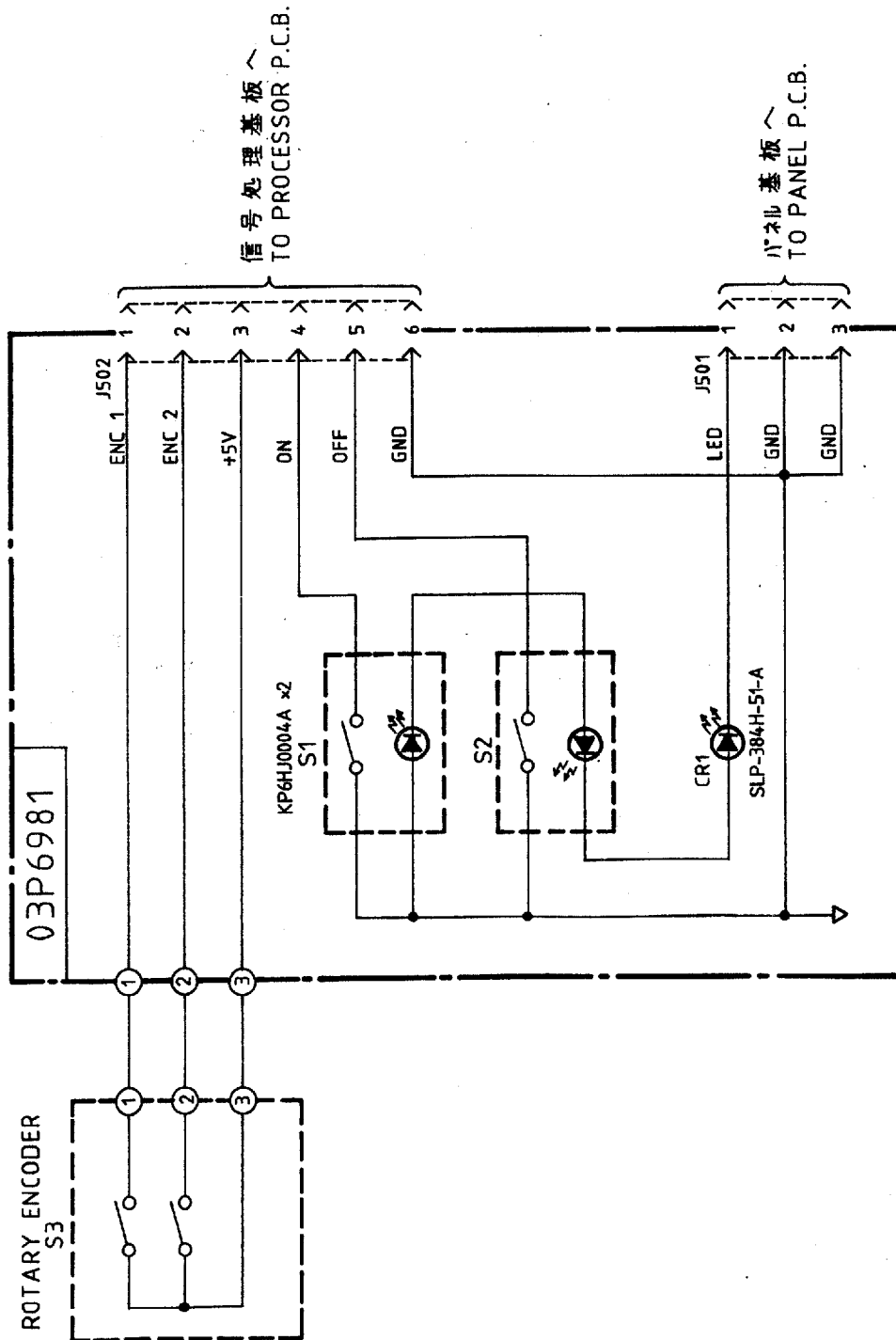

FR-1500DS SERIES
FR-1500D(A) SERIES

承認 APPROVED	MAY. 7. '87 I. Amano	名称 TITLE	EBL, VRM 基板 03P6981
検図 CHECKED	MAY. 7. '87 I. Amano		EBL, VRM P.C.B.
製図 DRAWN	May. 6. '87 Y. Tomiyama	図番 DWG. NO.	C3307-008-B

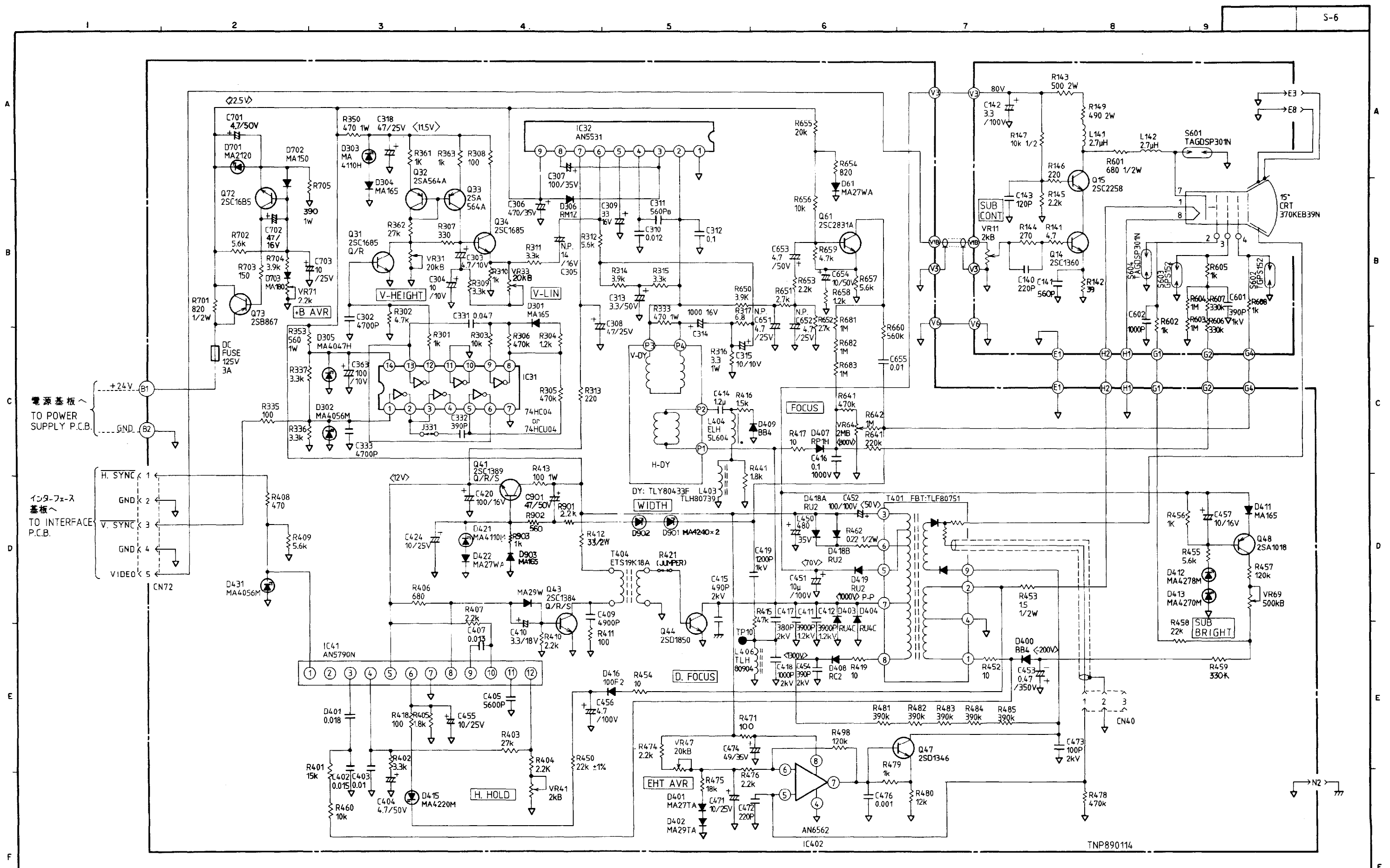

NOTE : 1. 特記なき抵抗は全てΩ, コンデンサはμF.
 ALL RESISTANCE IN OHMS AND CAPACITANCE IN MICRO FARAD UNLESS NOTED OTHERWISE.

承認 APPROVED	検図 CHECKED	名義 TITLE
T. YAKANE	I. Amano	TR-1523X9A CRT ディスプレイ CRT DISPLAY
検図 DRAWN	図番 DWG. NO.	
June 9 1987	C3307-021-E	

FR-1500DS SERIES
 FR-1500DIA) SERIES

TNP890114

A
B
C
D

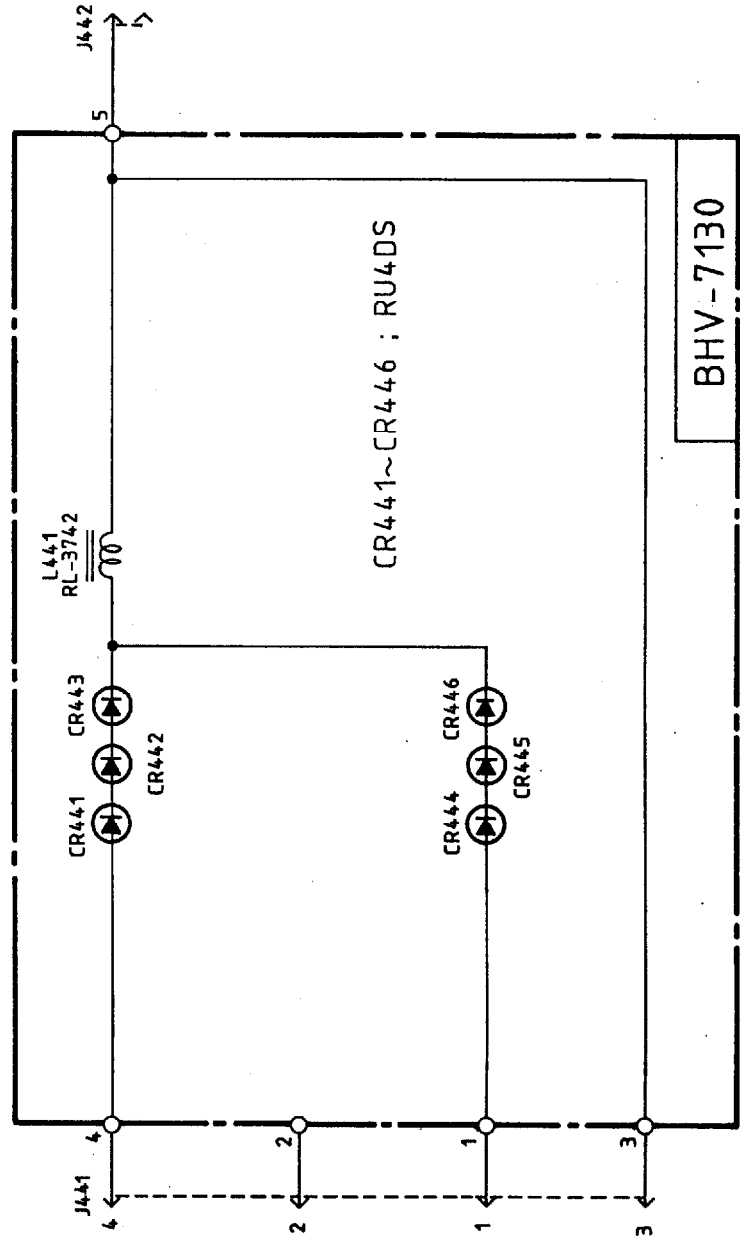

FOR 5kW/10kW RADARS

承認 APPROVED	APR. 24. '87 T. NAKANO	名称 TITLE	BHV-7130 送信 高压 TX HV
検査 CHECKED	APR. 23. '87 I. Amano		
製図 DRAWN	April. 23. '87 Y. Tomiyama	図番 DWG. NO.	C3307-005-H

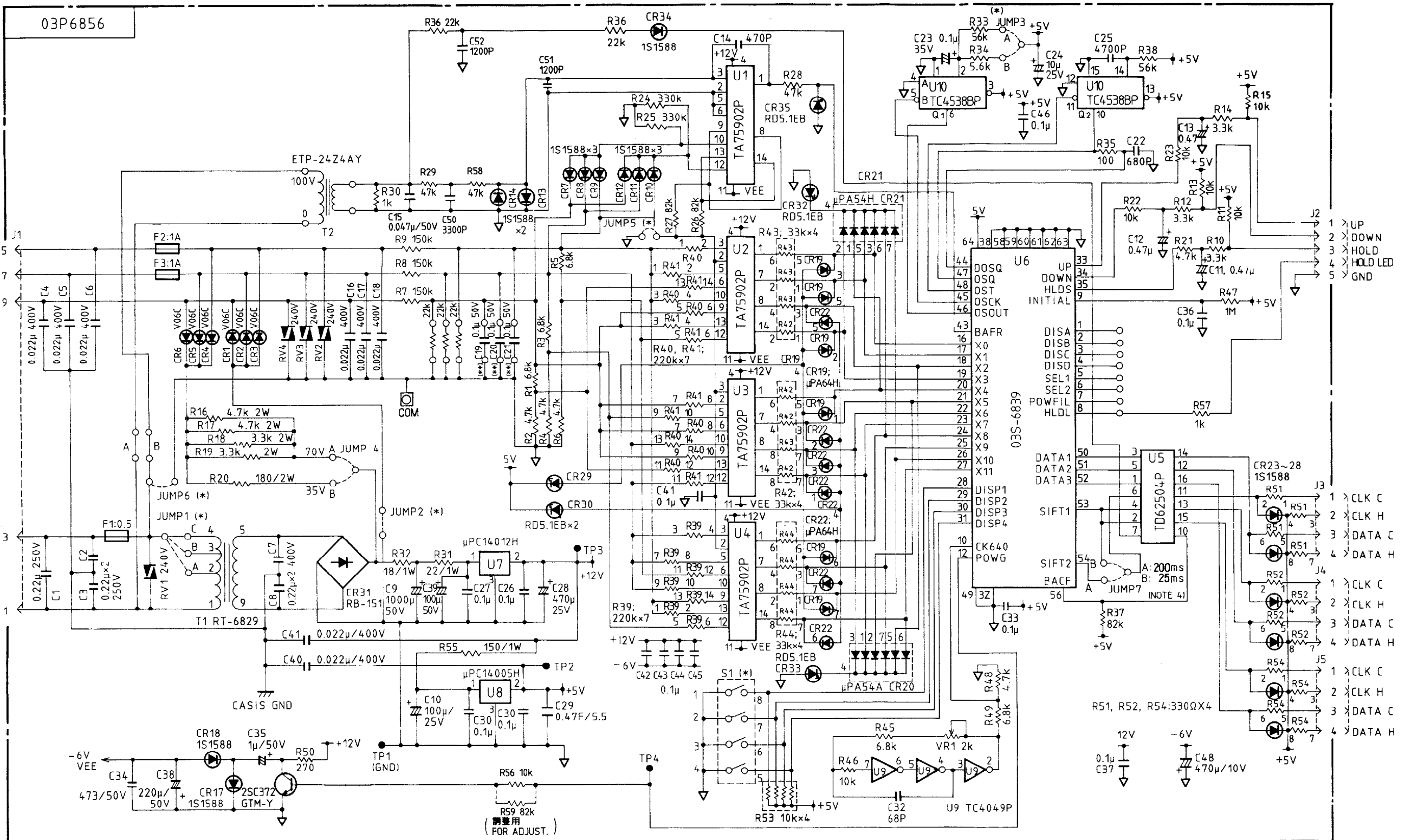

ジャイロ信号
GYROCOMPASS

シンクロ (ステップ)
SYNCHRO (STEP)

S1 (S1)
S2 (S2)
S3 (S3)

R1 (COM)
OV

R2 (NC)

J2 1 > UP
2 > DOWN
3 > HOLD
4 > HOLD LED
5 > GND

J3 1 > CLK C
2 > CLK H
3 > DATA C
4 > DATA H

J4 1 > CLK C
2 > CLK H
3 > DATA C
4 > DATA H

J5 1 > CLK C
2 > CLK H
3 > DATA C
4 > DATA H

NOTE 1: 特記なき抵抗の値は全てΩ, V4W, 又コンデンサはF.
ALL RESISTANCE IN OHMS, 1/4W, AND CAPACITANCE IN FARADS UNLESS NOTED OTHERWISE.

NOTE 2: ジャイロのタイプにより右の表の様にはジャンパ接続及び
(*) ディップスイッチの設定が変わる。
CHANGE THE JUMPER CONNECTIONS AND SETTING OF
DIP SWITCH ACCORDING TO TYPE OF GYRO COMPASS.
REFER TO TABLES AT RIGHT.

NOTE 3: 工事材料で支給。
(**) SUPPLIED FOR INSTALLATION MATERIALS.

JUMPER CONNECTIONS

	REF. VOLTAGE	JUMPER							
		Freq.	Volt	JUMP 1	JUMP 2	JUMP 3	JUMP 4	JUMP 5	JUMP 6
SYNCHRO TYPE	50/60 Hz	25V	○-○ A						
		50V	○-○ B						
	100V	○-○ C							
	400/500Hz	25V	○-○ A	OPEN					
	50V	○-○ B							
	100V	○-○ C							
STEP TYPE	EXT POWER (AC)	25V	○-○ A						
		50V	○-○ B						
	100V	○-○ C	OPEN	OPEN	OPEN	OPEN	OPEN		
STEP TYPE	EXT POWER (DC)		OPEN						
STEP TYPE	STEP SIG.	35V	OPEN	○-○ A					
		70V		○-○ B	○-○ A	OPEN	○-○		

☆: プラスコムの場合等で、外部電源を使用する時
WITH USING EXTERNAL POWER FOR POSITIVE COMMON TYPE, ETC.

SETTING OF DIP SWITCH

SIGNAL	SYNCHRO TYPE						STEP TYPE	
	50/60	400/500						
Freq. (Hz)	50/60	400/500						
Volt. (V)	25/50/100						35 70	
GYRO RATIO	360X	90X	36X	360X	90X	36X	180X	
	1	ON	ON	OFF	ON	ON	OFF	ON
	2	OFF	OFF	OFF	ON	ON	ON	ON
	3	ON	OFF	OFF	ON	OFF	OFF	ON
DIP SWITCH S1	4	OFF	OFF	OFF	OFF	OFF	ON	

NOTE 4: 出力データ転送周期(J3, J4, J5)
OUTPUT DATA TRANSMISSION INTERVAL.
J3 -----25msec/200msec
ジャンパ線(JUMP7)により切替可
SELECTABLE BY JUMP7.
J4, J5 -----25msec

承認 APPROVED
検図 CHECKED
製図 DRAWN

名 称 TITLE
03P6856 (GS-6856)
ジャイロインタフェース基板
GYRO INTERFACE PCB.

図 番 DWG. NO.
C3307-009-H

GC-1/2/6

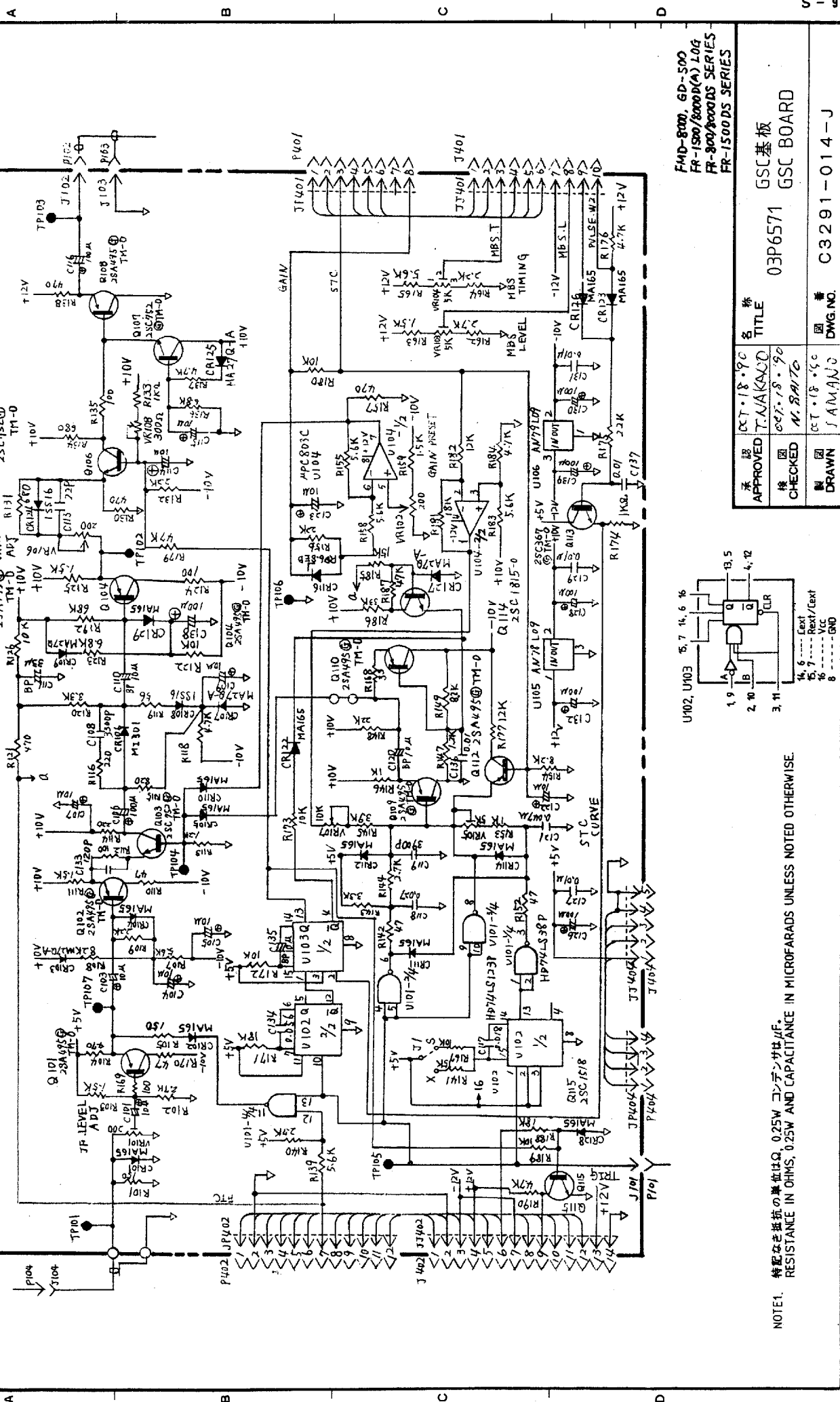

FMD-8000, GD-500
FR-1500/8000(A) LOG
FR-800/8000DS SERIES
FR-15000DS SERIES

承認書 APPROVED	設計者 T. YAKUNO	名称 TITLE	GSC基板 GSC BOARD
検査 CHECKED	検査者 M. SAITO	図番 DRAWING NO.	03P6571
製図 DRAWN	製図者 S. AMANO	国番 DWG. NO.	C3291-014-J

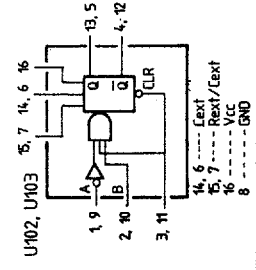

NOTE1. 特配な抵抗の単位はΩ, 0.25W コンデンサはpF.
RESISTANCE IN OHMS; 0.25W AND CAPACITANCE IN MICROFARADS UNLESS NOTED OTHERWISE.

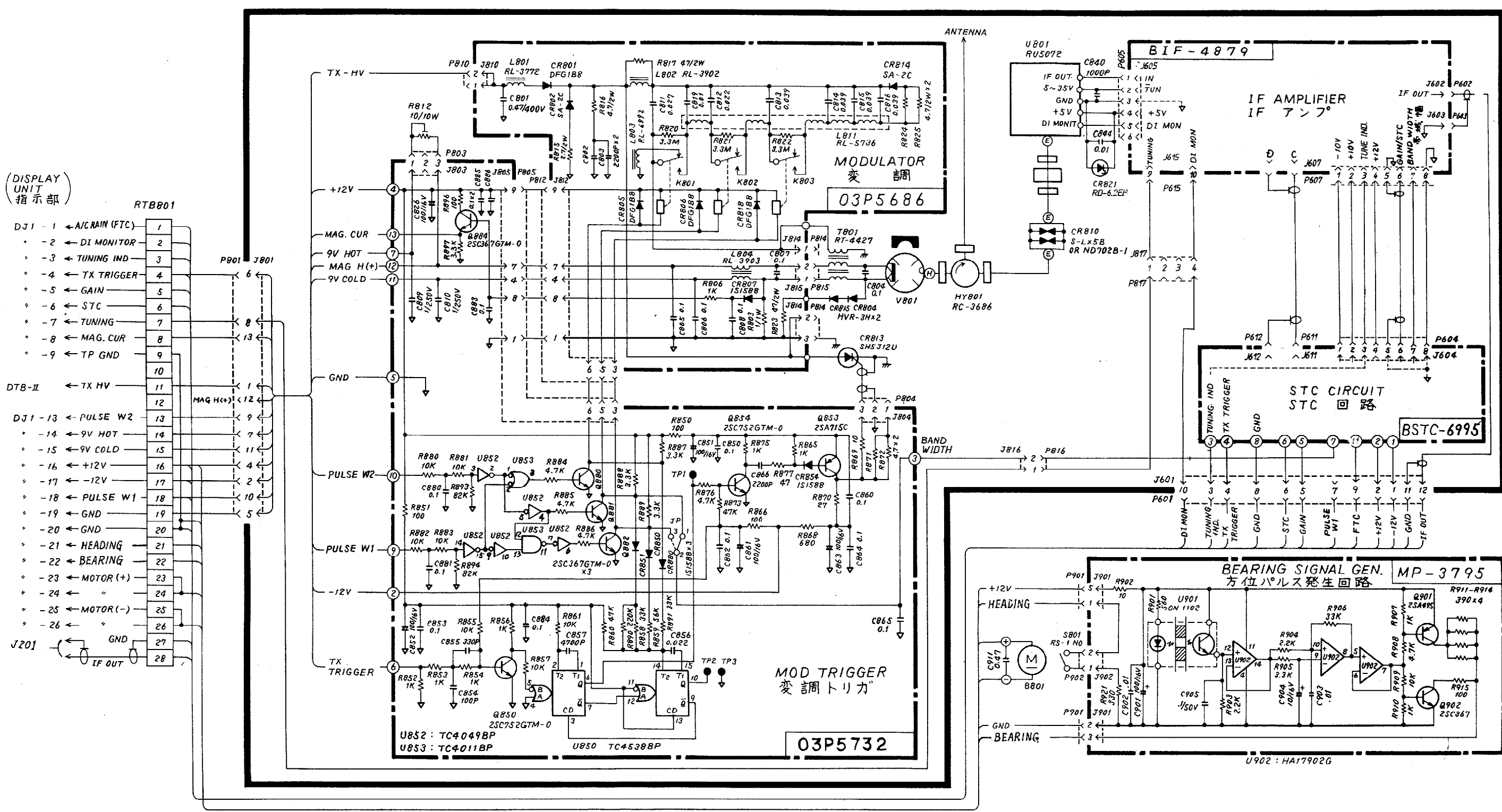

NOTE 1. 特記なき抵抗は全てΩ, 1/4W, コンデンサはμF.
 ALL RESISTANCE IN OHMS, 1/4W, CAPACITANCE IN MICRO FARADS
 UNLESS NOTED OTHERWISE.

承認 APPROVED	検図 CHECKED	製図 DRAWN	承認 APPROVED	検図 CHECKED	製図 DRAWN	三角法 THIRD ANGLE PROJECTION	尺 SCALE	重量 WEIGHT	kg	名称 TITLE	図番 DWG. NO.
										SCANNER UNIT 空中線部	C3307-013-G

FR-8050D/8100D
 FR-1505D/1510D

(DISPLAY UNIT 指示部)

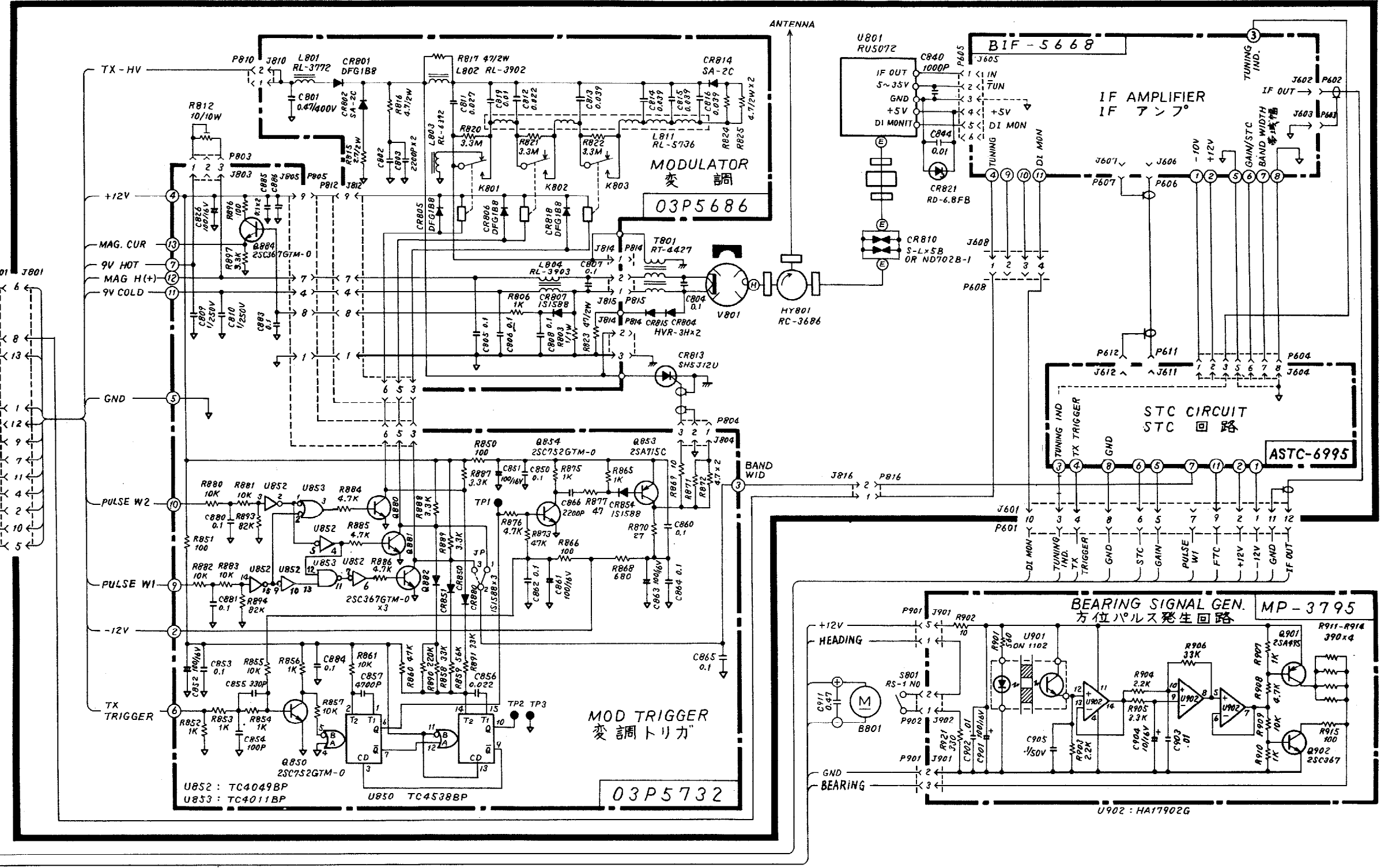
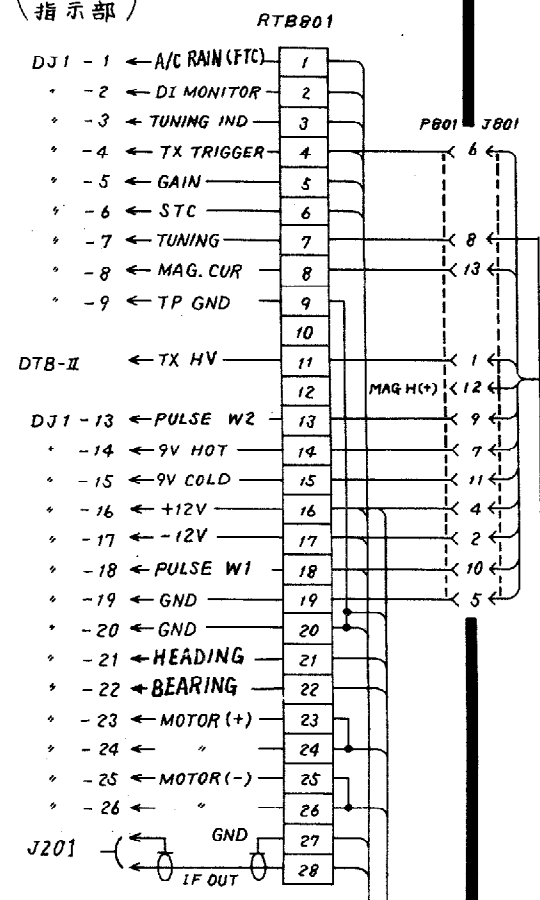

NOTE 1. 特記なき抵抗は全てΩ, 1/4W, コンデンサはμF.
 ALL RESISTANCE IN OHMS, 1/4W, CAPACITANCE IN MICRO FARADS
 UNLESS NOTED OTHERWISE.

FR-8050DA/8100DA
 FR-1505DA/1510DA

承認 APPROVED	MAY-14-87 I. ANANO	三角法 THIRD ANGLE PROJECTION	名称 TITLE
検図 CHECKED	MAY-14-87 I. ANANO	尺度 SCALE	SCANNER UNIT 空中線部
製図 DRAWN	MAY-14-87 Y. TEMIYAMA	重量 WEIGHT	kg
			図番 DWG. NO. C3307-016-G

(DISPLAY UNIT 指示部)

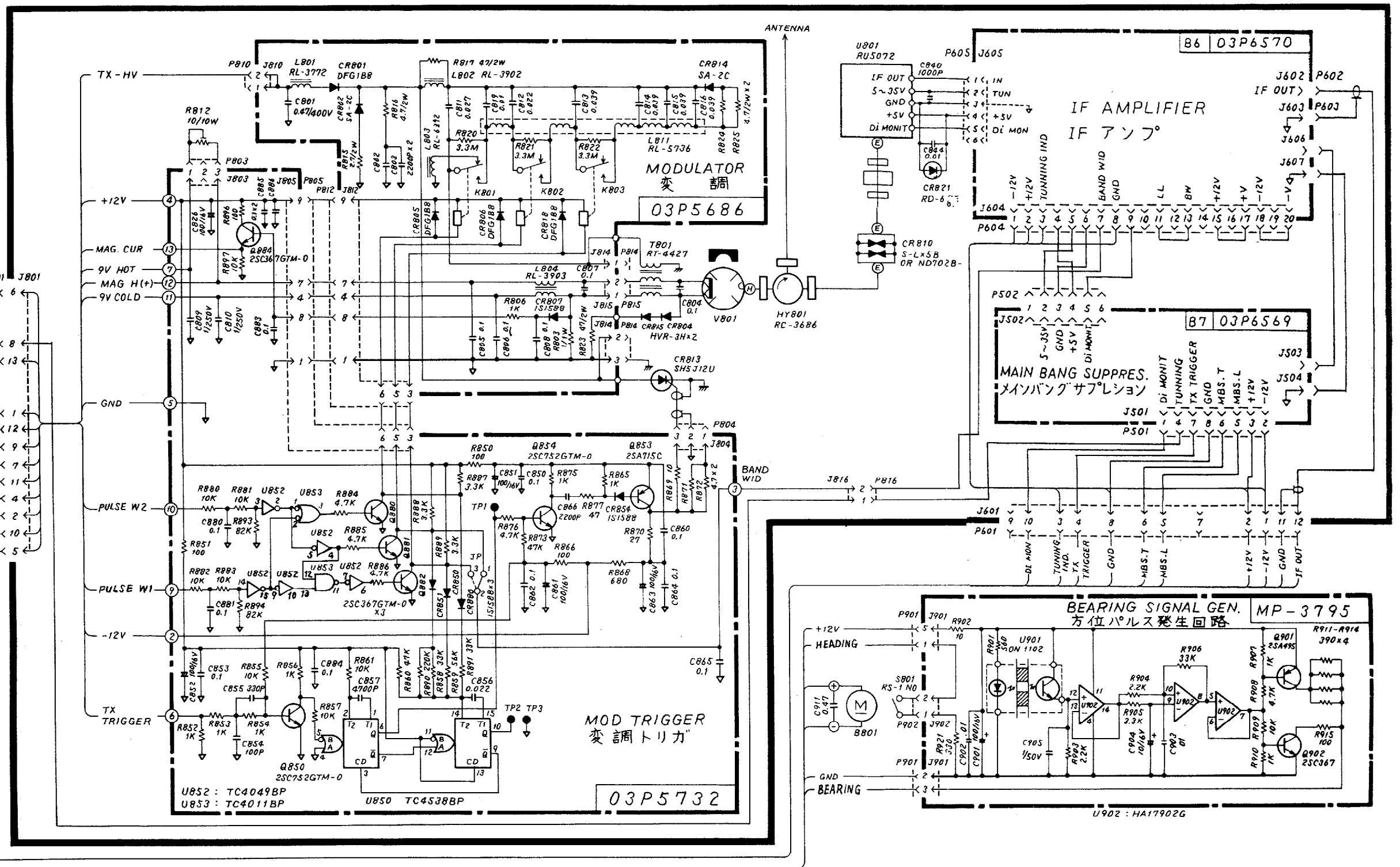
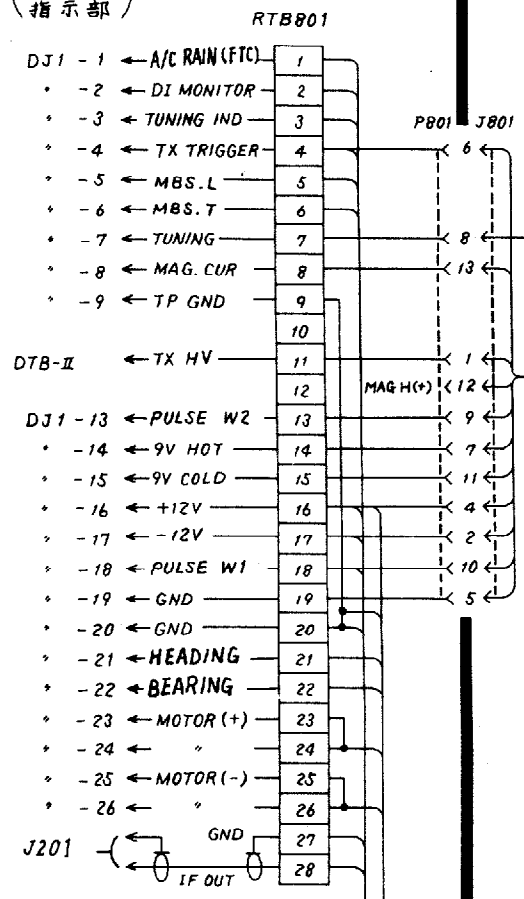

NOTE 1. 特記なき抵抗は全てΩ, 1/4W, コンデンサはμF.
 ALL RESISTANCE IN OHMS, 1/4W, CAPACITANCE IN MICRO FARADS
 UNLESS NOTED OTHERWISE.

承認 APPROVED	MAKAWA	三角法 THIRD ANGLE PROJECTION	名称 TITLE
検閲 CHECKED	May-14-87 I. Amano	尺 SCALE	SCANNER UNIT 空中線部 (ログアンプ)
製図 DRAWN	May-14-87 Y. Tomiyama	重量 WEIGHT	kg
	FR-8050DA/8100DA 1510DA	図番 DWG. NO.	C3314-K03-A

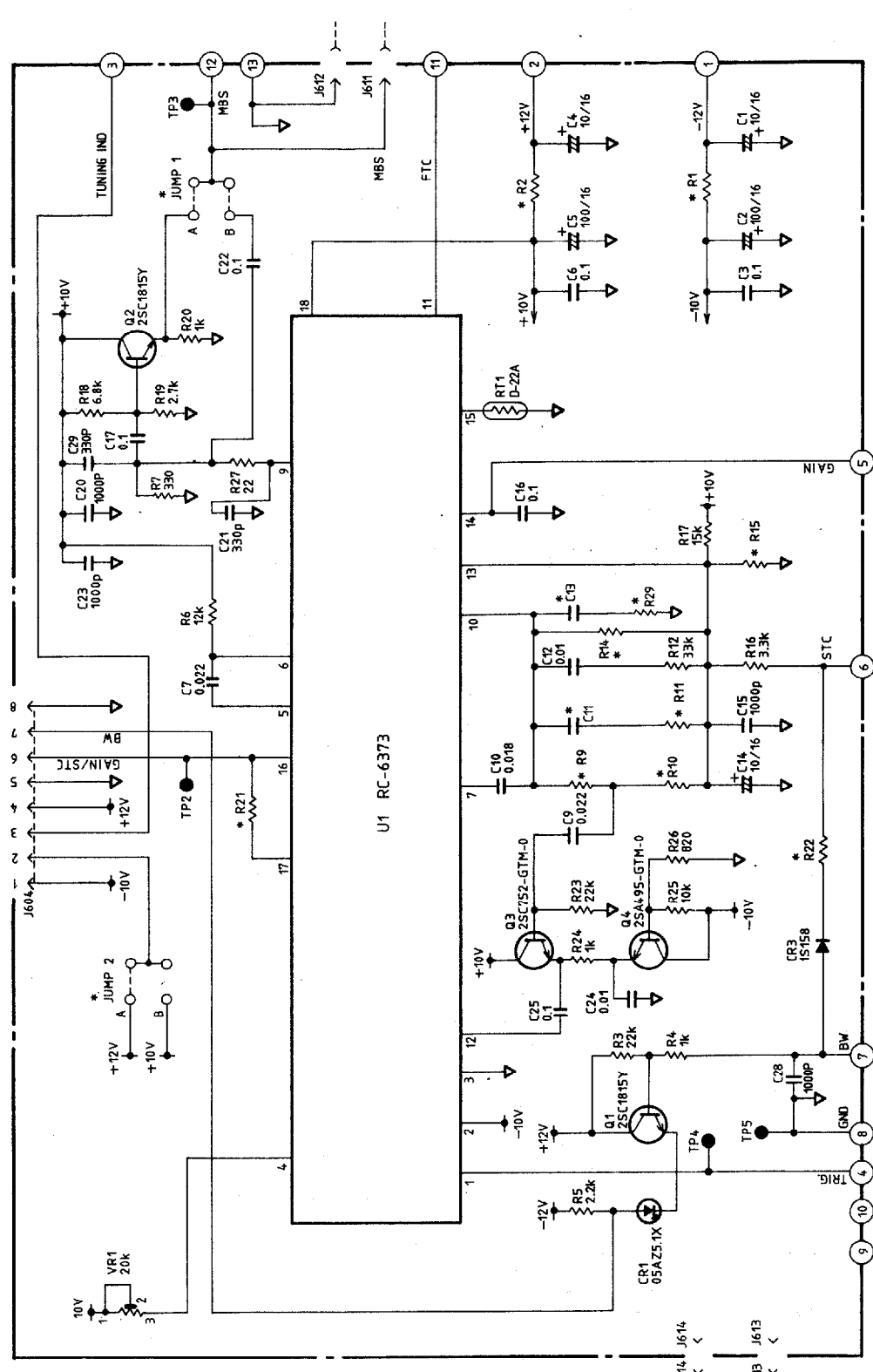

NOTE: 1. 特記無き抵抗の単位は全て Ω , $1/4W$, コドテンは μF , コイルは H.
 ALL RESISTANCE IN OHMS $1/4W$, CAPACITANCE IN MICRO FARADS AND INDUCTANCE IN HENRY UNLESS NOTED OTHERWISE.

2. (*)

JUMP 1	JUMP 2	R1	R2	R9	R11	R21	R22	C11	R15	C27	R29	C13	R10	R16
B	B	68 Ω	27 Ω	8.2k Ω	1.8k Ω	33 Ω	—	3300PF	10k Ω	1800PF	100 Ω	220PF	4.7k Ω	2k Ω
A	A	56 Ω	56 Ω	6.8k Ω	1.5k Ω	22 Ω	22k	8200PF	—	—	—	—	8.2k Ω	—

3. コネクタを除く基板内部品の部品番号は700番台。
 ADD 700 TO PARTS NUMBER EXCEPT FOR CONNECTORS.

承認 APPROVED	検査 CHECKED	設計 DRAWN	検査 DRAWN	名 TITLE	番 DWG. NO.
1977.05.27	1977.05.27	1977.05.27	1977.05.27	ASTC-6995 BSTC-6995	C3307-011-J
T. NAKAGAWA			J. Amano		
STC 基板			STC P.C.B.		

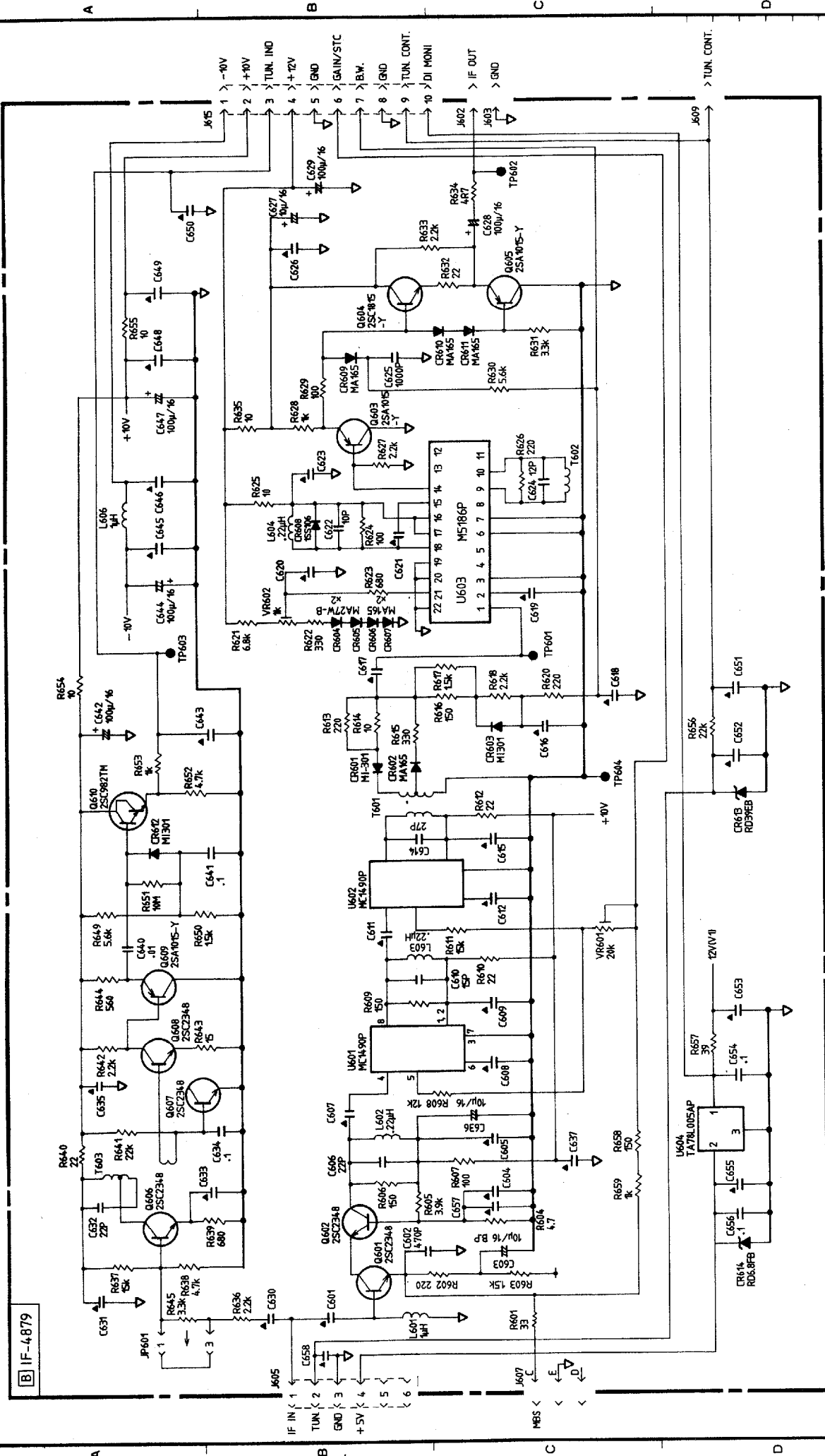

承認 APPROVED	名 稱 TITLE
検 査 CHECKED	BIF-4879 IF AMPLIFIER
製 図 DRAWN	図 番 DWG. NO.
	C3314-K01-D

注1. ▲ : 0.01μF, 50V
 2. 特記なき抵抗の単位はΩ, 1/6W
 又, コンデンサはμF.

NOTE1. ▲ : 0.01μF, 50V
 2. ALL RESISTANCE IN Ω, 1/6W AND
 CAPACITANCE IN μF UNLESS NOTED
 OTHERWISE.

FR-8000 SERIES
 FR-15000 SERIES

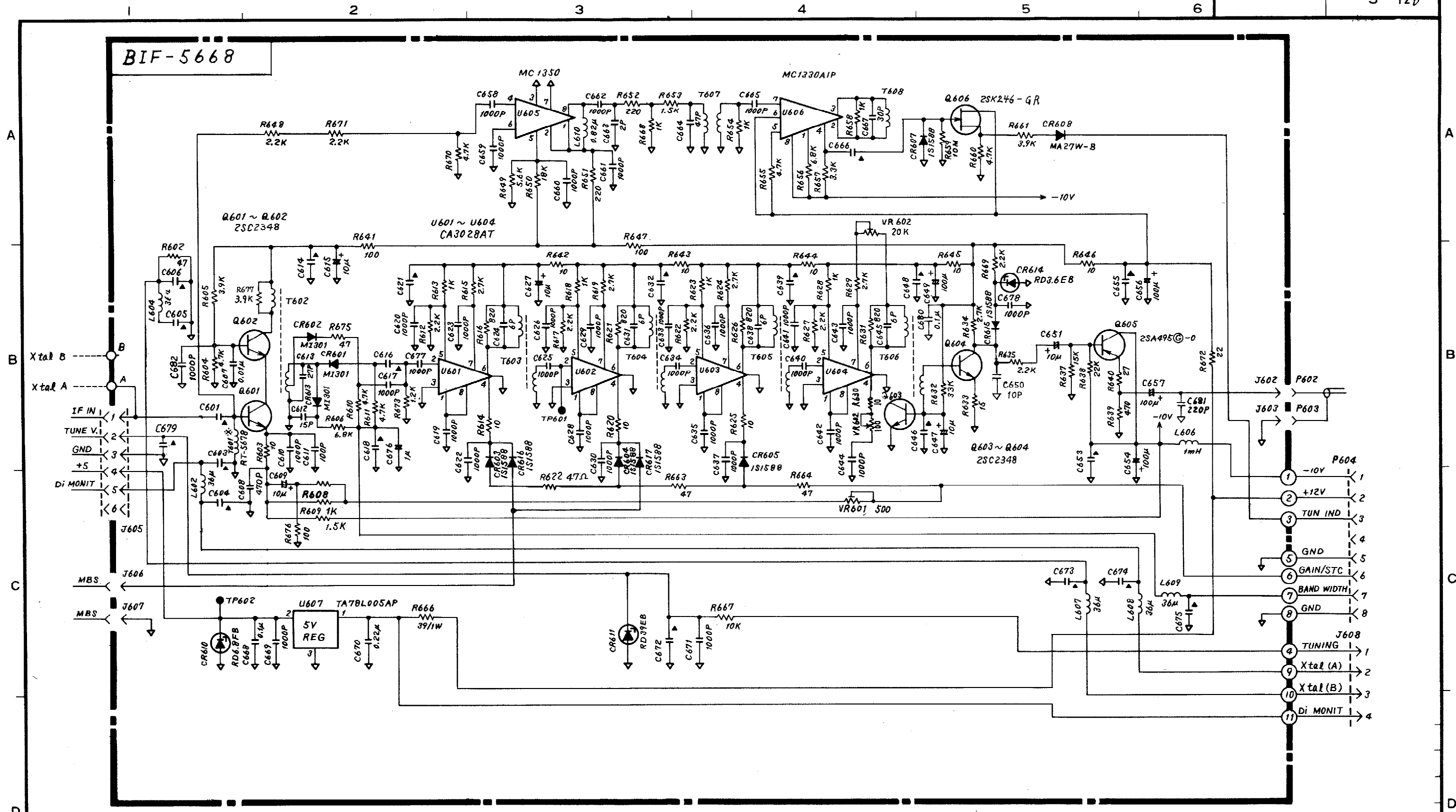

NOTE 1. 特記なき抵抗は全てΩ, 1/4W コンデンサは F, コイルは H.
 ALL RESISTANCE IN OHMS 1/4W, CAPACITANCE IN FARADS
 AND INDUCTANCE IN HENRIES UNLESS NOTED OTHERWISE.

2. ▲ : 0.01μF, 50V

FR-8000DA SERIES
 FR-1500DA SERIES

品番 ITEM	品名 NAME	材質 MATERIAL	数量 Q'TY	図番 DWG.NO.	摘要 REMARKS
承認 APPROVED	MAAF-19-89 7.2AKK60	三角法 THIRD ANGLE PROJECTION		名称 TITLE	IF アンプ IF AMPLIFIER (BIF-5668)
検図 CHECKED	May-19-87 I. Amano	尺度 SCALE		重量 WEIGHT	kg
製図 DRAWN	May-18-82 Y. Tomiyama			図番 DWG.NO.	C3307-014-K

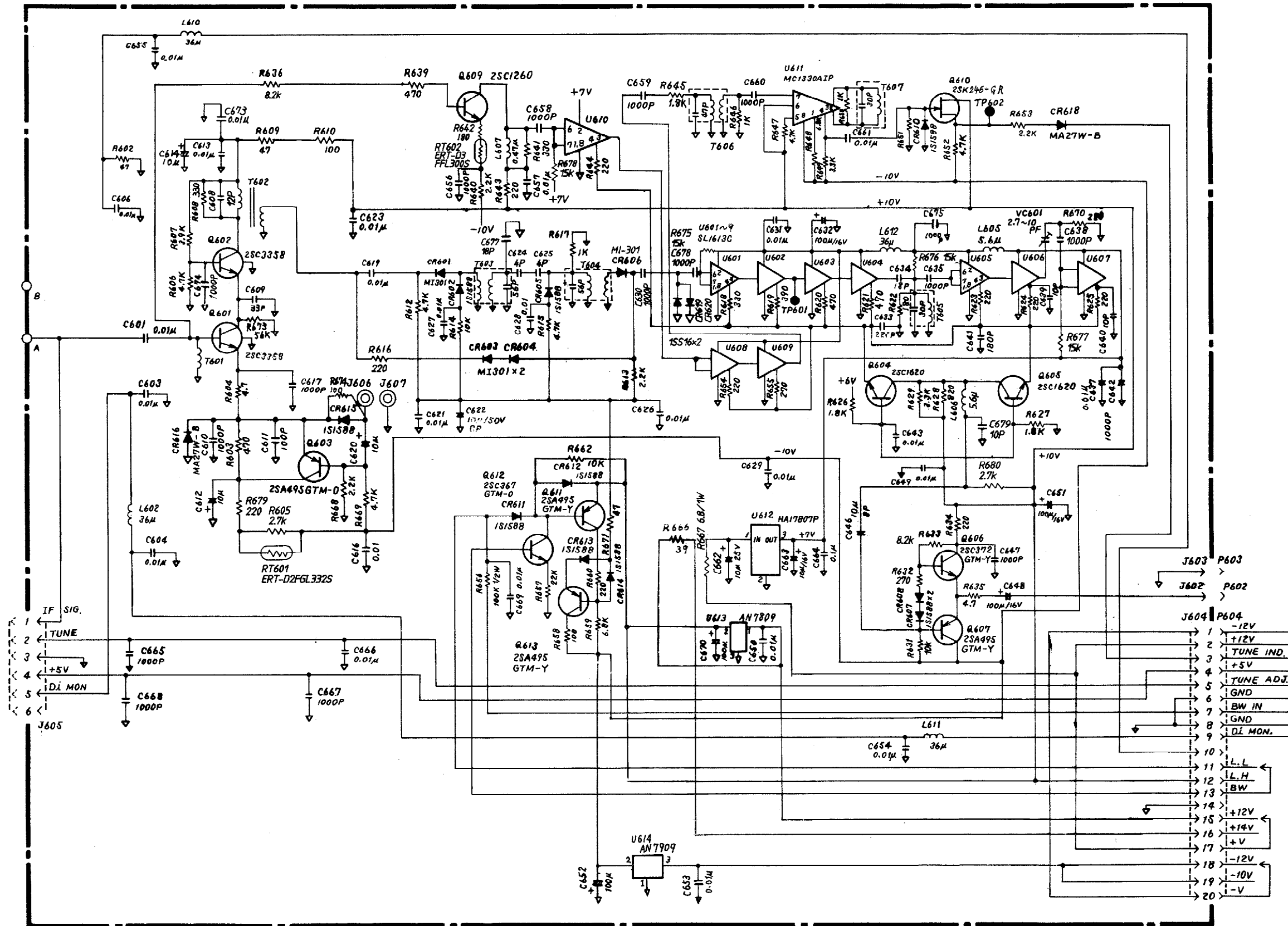

NOTE 1. 特記なき抵抗は全て Ω , 1/4W コンデンサはF, コイルはH.
 ALL RESISTANCE IN OHMS 1/4W, CAPACITANCE IN FARAD
 AND INDUCTANCE IN HENRY UNLESS NOTED OTHERWISE.

FR-1460DS/1430DS/1410DS
 FCR-1400 MB (LOG) SERIES
 FR-1500 (LOG) / 8000 (LOG) SERIES
 FR-2030S, FR/FAR-2830S/2860S
 FR-800DS/1500DS/8000DS SERIES

承認 APPROVED	APR. 10. 84	名称 TITLE	IF アンプ基板
検閲 CHECKED	FEB. 14. 84		IF AMPLIFIER BOARD 03P6570
製図 DRAWN	FEB. 14. 84	図番 DWG. NO.	C3291-006-5

REV.: 9/86, 2/87

A

B

C

D

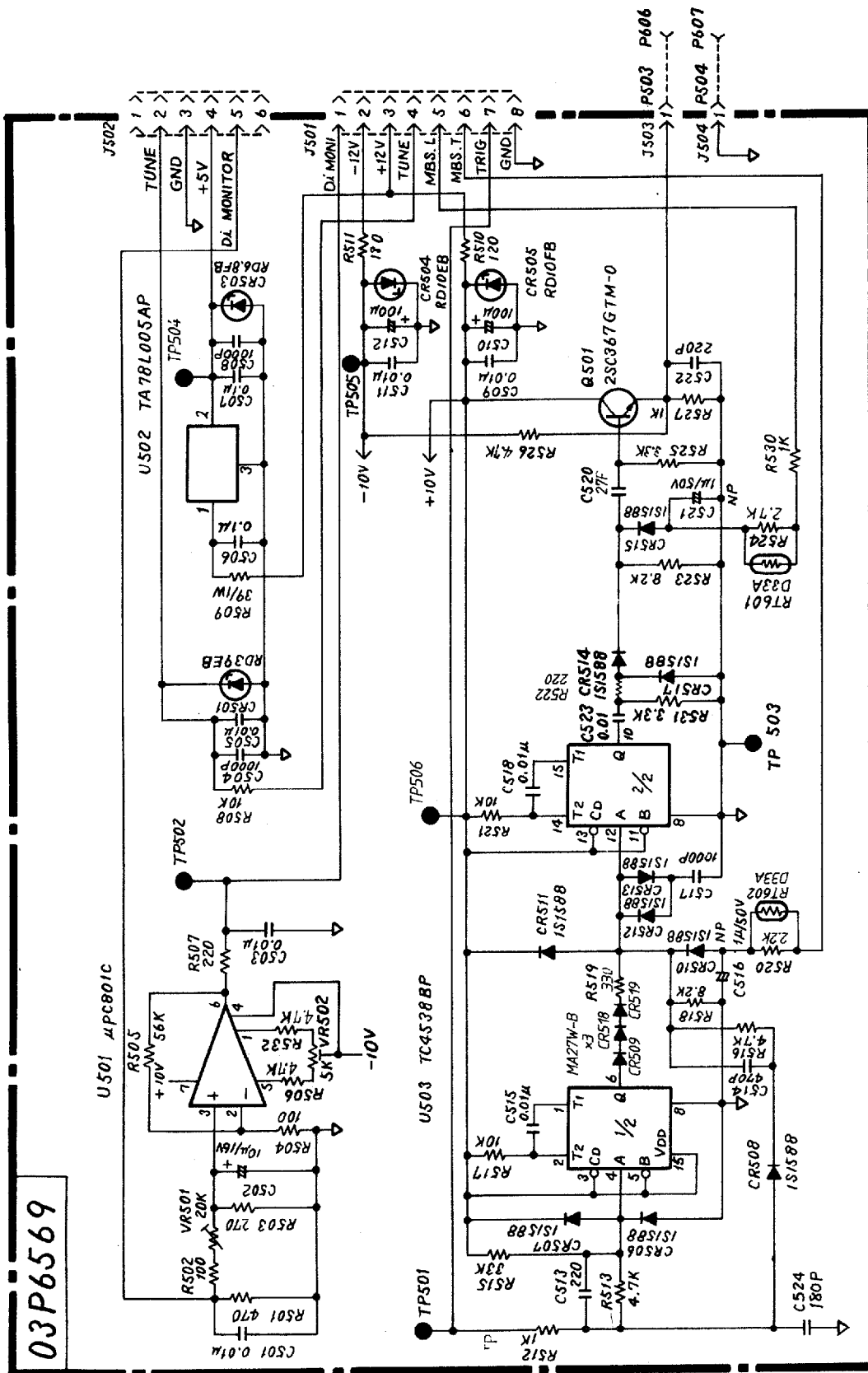

03P6569

FR-1460DS/1430DS/1410DS
 FCR-1400M3 (LOG) SERIES
 FR-1500 (LOG) / 8000 (LOG) SERIES
 FR-2030S, FR/FAR-2830S/2860S
 FR-800DS/1500DS/8000DS SERIES

NOTE: 特記なき抵抗の単位は全てΩ, 1/4W 又コンデンサは F.
 ALL RESISTANCE IN OHMS, 1/4W AND CAPACITANCE
 IN FARADS UNLESS NOTED OTHERWISE.

品番 ITEM	品名 NAME	材質 MATERIAL	数量 Q'TY	図番 DWG.NO.	摘要 REMARKS
承認 APPROVED	三角法 THIRD ANGLE PROJECTION	名称 TITLE	03P6569		
検 CHECKED	尺 SCALE	メインバンク サプレッション基板 MAIN BANG SUPPRESSION BOARD			
製 DRAWN	重 WEIGHT	kg	図番 DWG.NO.	C3291-003-J	